

NATIONAL-SPENCER, INC.

ZEE LINE LUBRICATION EQUIPMENT

Phone 800-231-1525

Fax 800-637-9511

Web Address www.zeeline.com



Part #1475R

1/2" x 32 ft.

Oil

Standard Duty Hose Reel

For dispensing product in an environment that eliminates dangerous and unsightly tangled hoses

Overall dimensions

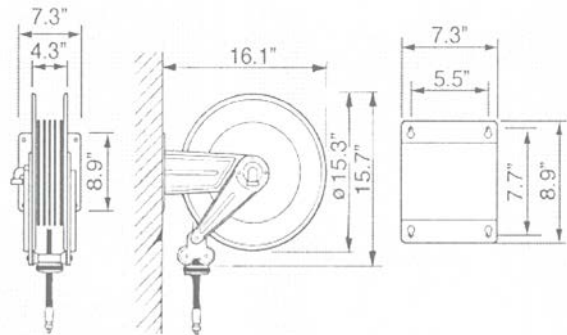

Features

- ❖ Heavy-duty 1/4" plate steel support post
- ❖ 1" diameter steel axle
- ❖ Cartridge style spring motor
- ❖ Adjustable arm guide (wall, floor, ceiling, pit)
- ❖ Four-roller non-snap hose guide
- ❖ Eight-position locking ratchet
- ❖ 1" self-lubricating bearing
- ❖ Maximum pressure 2500 psi
- ❖ Maximum temperature 250° F
- ❖ 1/2" x 32 ft. one wire braid hose included (3/4" O.D.)
- X Do not exceed listed hose O.D. to obtain maximum hose length

Recommended for

- ✓ Oil

Application

- Automotive
- Agriculture
- Industrial

Number of boxes and contents

- ❑ Reel and hose 1 box (20" x 18" x 9") (49 lb.)
- ❑ UPC Code 0 1595441475 9