

Part Number: M1900, Rev. 8

Issue Date: 12/4/2018

Supersedes: 5/3/2017



# **M1900 - Petro Vend 100<sup>®</sup> Fuel Control System**

## Installation, Operation and Maintenance Guide

3.01.03f/2.01m



**NOTE:** Before you use this guide, make sure you have the latest revision. Check the revision level of this document against the most current revision found at <http://www.opwglobal.com/opw-fms/tech-support/manuals-how-to-videos> . Download the latest revision if necessary.



OPW Fuel Management Systems is a part of Dover Fueling Solutions.

## Copyright Information

Copyright © 2018 Delaware Capital Formation, Inc. All Rights Reserved. DOVER, the DOVER logo are registered trademarks of Delaware Capital Formation, Inc., a wholly-owned subsidiary of Dover Corporation.

## Contact OPW Fuel Management Systems

Visit us at [www.opwglobal.com](http://www.opwglobal.com), or contact us at:

Call 1-877-OPW-TECH (877-679-8324)

For calls outside US and Canada, call +1-708-485-4200

Monday through Friday, 7 a.m. to 6 p.m., US CST

For technician registration, see

<http://opwglobal.com/TechSupport/TechnicianRegistration.aspx>.

For in-depth training via OPW University, see

<http://www.opwglobal.com/opw-u-training-registration.html>.



## Table of Contents

Section 1 Precautions .....	6
1.1 USB Flash Drives .....	6
1.2 Safety Warnings .....	8
1.3 Hazardous Areas .....	9
1.3.1 NFPA/NEC – Class I, Div. 1 & Div. 2 .....	9
1.3.2 Installation Requirement .....	10
1.4 FCC Compliance .....	12
Section 2 Introduction .....	13
2.1 Terminology .....	13
2.2 Versioning .....	13
2.3 System Technical Specifications .....	14
2.3.1 Fuel Control System .....	14
2.4 Pump Control .....	15
2.4.1 Mechanical Pump Control .....	15
Section 3 Pre-Installation Information .....	16
3.1 Conduit/Wiring Requirements .....	16
3.1.1 Conduit Sealing .....	16
3.1.2 Pedestal Conduits .....	17
3.1.3 Grounding .....	17
3.1.4 PV100® Power Requirements .....	18
3.1.5 Pulser Wire .....	18
Section 4 System Installation .....	19
4.0.1 Typical Installation Overview .....	19
Section 5 Mechanical PCM Pump Control .....	22

5.1 Power Conduit Installation .....	22
5.2 PCM Conduit Installation .....	23
5.2.1 Pump Control/Pulser Conduit .....	23
5.2.2 Pump Pulser Conduit .....	23
5.3 System Power Wiring .....	23
5.4 PCM Pump Dispenser Wiring .....	24
5.4.1 Pump/Dispenser Wiring .....	24
5.4.2 Pump/Dispenser Pulser Wiring .....	26
5.5 PCM Startup/Configuration .....	26
5.5.1 Configuration (DIP Switches) .....	26
5.5.2 PCM Testing .....	28
Section 6 Complete the Installation .....	30
Section 7 System Configuration .....	31
7.1 Terminal Setup/Test Menu .....	31
7.1.1 Display Menu .....	32
7.1.2 Keypad Menu .....	32
7.1.3 Reader Menu .....	33
7.1.4 Tones Menu .....	33
7.1.5 System Network Number Menu .....	34
7.1.6 Petro-Net™ Setup Menu .....	34
7.1.7 Miscellaneous Menu .....	34
7.1.8 Pump Control Menu .....	35
7.1.9 Software Updates .....	36
7.2 Management Menu .....	36
7.2.1 Site Management .....	37

7.3 Pump Management .....	40
7.4 Proprietary Card File (PCF) Management .....	41
7.4.1 Clearing Totals .....	43
7.4.2 Reporting .....	44
7.5 Dual Card Security Feature .....	49
Section 8 System Maintenance .....	55
Appendix A - PV100® Primary Board .....	56
Appendix B - Termination Codes .....	57
Appendix C - Menu of Display Screens .....	59
Warranty .....	63

## Section 1 Precautions

### 1.1 USB Flash Drives

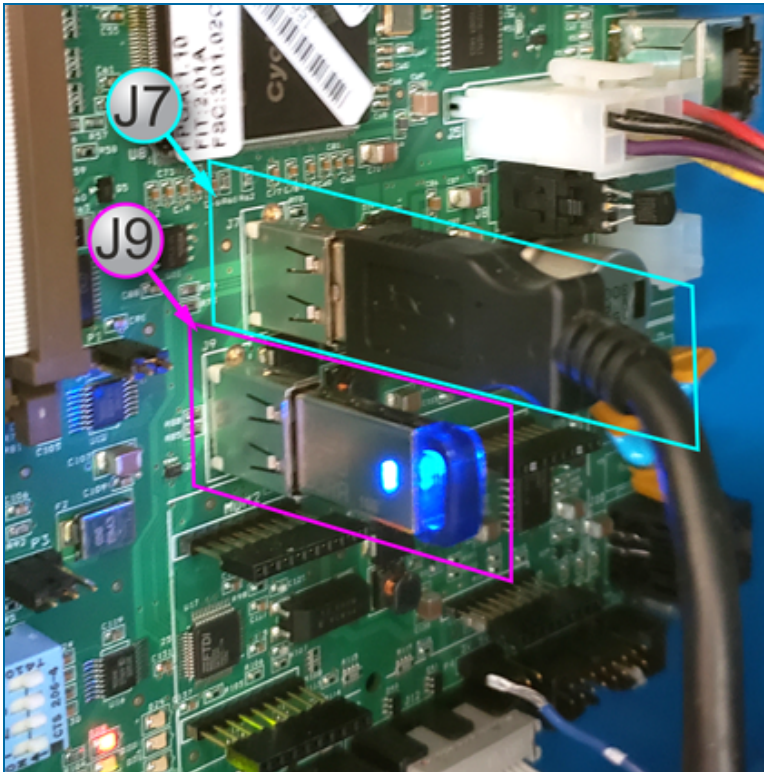

There are two (2) internal USB ports on the PV100 Main Board.

The J7 USB port (top) is used to connect the Main Board to the Door Port with the installed cable.

The J9 USB port (bottom) is for the provided metal industrial-grade USB key that is used to store data for Totals and Transactions.



**NOTICE:** Use the metal industrial-grade USB Flash Drive that was provided with your unit to store Totals and Transactions. Use this key only in the PV100 J9 USB port to prevent loss of data.

To prevent data loss **DO NOT** use the plastic *Manuals* USB key (identified by the OPW "diamond" logo) in the USB ports of the PV100. This key must only be used in a PC.



**IMPORTANT:** The sub-sections that follow contain important safety and compliance information related to the installation and operation of this unit. Read these instructions carefully before you continue with the installation.

## 1.2 Safety Warnings

This manual contains many important Safety Alerts. There can be a risk of injury or damage to property if you do not obey these alerts. The panels below show the types of safety warnings that can be seen and how each is specified.



**DANGER:** Indicates an immediately hazardous condition that, if not prevented, will result in death or serious injury.



**WARNING:** Indicates a possibly hazardous condition that, if not prevented, could result in death or serious injury.



**CAUTION:** Indicates a possibly hazardous situation that, if not prevented, could result in minor or moderate injury.



**NOTICE:** Indicates important information not related to hazards.



## 1.3 Hazardous Areas

Any fuel dispenser is a hazardous area as defined in the National Electrical Code. Installation must be in accordance with the following:

- National Electrical Code (NFPA No. 70)
- Motor Fuel Dispensing Facilities and Repair Garages Code (NFPA No. 30A)

### 1.3.1 NFPA/NEC – Class I, Div. 1 & Div. 2

The Class I, Division 1 and Class I, Division 2 hazardous areas are specified below:

**Class I locations.** Class I locations are those in which flammable gases or vapors are or may be present in the air in quantities sufficient to produce explosive or ignitable mixtures. Class I locations include the following:

1. **Class I, Division 1.** A Class I, Division 1 location is a location:
  - a. In which ignitable concentrations of flammable gases or vapors may exist under normal operating conditions.
  - b. In which ignitable concentrations of such gases or vapors may exist frequently because of repair or maintenance operations or because of leakage.
  - c. In which breakdown or faulty operation of equipment or processes might release ignitable concentrations of flammable gases or vapors, and might also cause simultaneous failure of electric equipment.
2. **Class I, Division 2.** A Class I, Division 2 location is a location:
  - a. In which volatile flammable liquids or flammable gases are handled, processed, or used, but in which the hazardous liquids, vapors, or gases will normally be confined within closed containers or closed systems from which they can escape only in case of accidental rupture or breakdown of such containers or systems, or in case of abnormal operation of equipment; or
  - b. In which ignitable concentrations of gases or vapors are normally prevented by positive mechanical ventilation, and which might become hazardous through failure or abnormal operations of the ventilating equipment; or
  - c. That is adjacent to a Class I, Division 1 location, and to which ignitable concentrations of gases or vapors might occasionally be communicated unless such communication is prevented by adequate positive-pressure ventilation from a source of clean air, and effective safeguards against ventilation failure are provided.



**WARNING:** To prevent possible fire or explosion, do not mount your system site controller or any other electrical part of the system, including printers and modems, within or above the defined "hazardous" areas.





**IMPORTANT:** It is the installer's responsibility to know and obey all local codes.

OPW Fuel Management System's fuel control systems are listed for use in a non-classified area. All of the equipment must be installed outside of the hazardous areas.



**NOTE:** Local codes can dictate specific installation requirements. Installation is subject to approval by the local authority that has jurisdiction at the site.

### 1.3.2 Installation Requirement

OPW Terminals are designed to be installed above the hazardous area when using the terminal's associated pedestal.

The pedestal can be mounted in the hazardous area but a seal-off must be the first fitting for all conduits that go into the area.



**IMPORTANT:** All unused knockout holes that have been removed must be sealed.

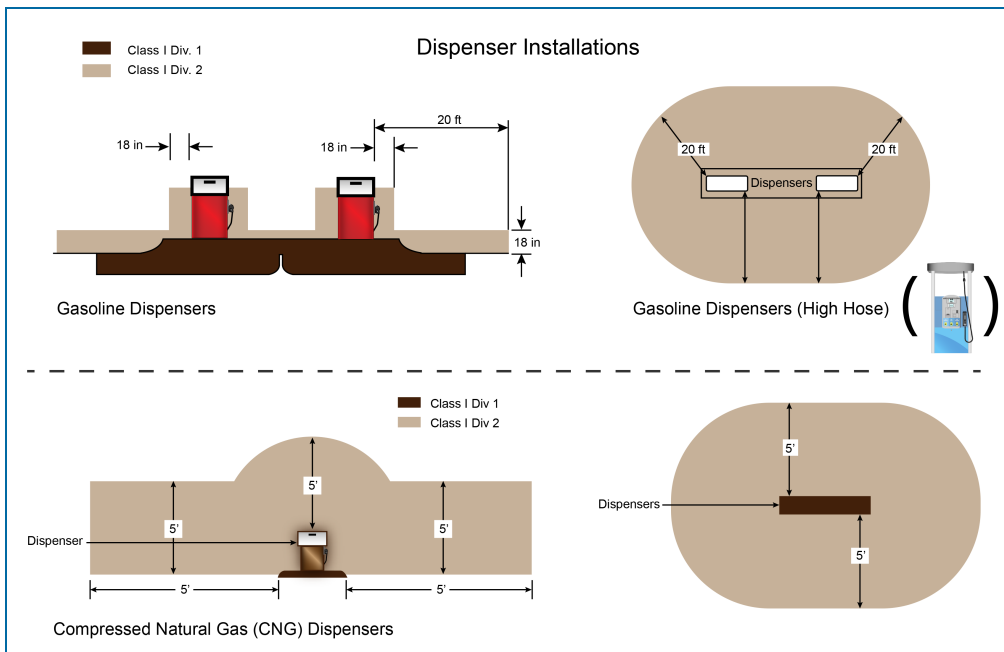

Figure 1-1 Dispenser Installations



**WARNING:** Knockouts and installation hardware are provided for all cabinetry. Do **NOT** drill holes in the enclosures. This would violate the safety listing of the system.



**CAUTION:** Be sure to wear all required personal protective equipment (PPE). This includes safety glasses, hardhat, safety shoes and reflective vest.

Barricade the work area before installation.

Be sure to obey all applicable Lockout/Tagout (LOTO) procedures before installation.



**IMPORTANT:** It is recommended to do a check of the electrical system with a multimeter to make sure all connections are de-energized before you proceed with the installation.

## 1.4 FCC Compliance

This system complies with Part 15 of the Federal Communications Commission (FCC) Rules & Regulations. Operation is applicable to these conditions:

- This device must not cause harmful interference.
- This device must accept interference received, including interference that can cause undesired operation.

## Section 2 Introduction

This installation, operation and maintenance (IOM) manual details the installation startup, testing, configuration, and general troubleshooting instructions for the PV100<sup>®</sup> Fuel Control System by OPW Fuel Management Systems. The PV100<sup>®</sup> system is designed with an integrated fuel-site controller to control the system operation.

The PV100<sup>®</sup> provides a turnkey system; the only configuration required for immediate use after installation is configuration of the network number. Upon network number configuration, all purchased cards can be manually configured with unique PINs on the first use of the card. After configuration of the card's PIN, a second swipe will provide access to purchased pumps within the system.

### 2.1 Terminology

The abbreviations below identify terms assigned to specific components and functions within the Fuel Control System.

- **Fuel Island Terminal (FIT):** Generic term used to describe the fuel management system.
- **Fuel Site Controller (FSC):** Hardware/firmware used to control the fueling system.
- **Pump Control Module (PCM) Slave:** Hardware used for controlling mechanical pumps.
- **Direct Pump Control (DPC):** Hardware used for communicating to electronic pumps.

### 2.2 Versioning

The PV100<sup>®</sup> uses two (2) separate pieces of software. One controls the Fuel Island Terminal (FIT) and Pump Control Module (PCM), and another controls the operation of the Fuel Site Controller (FSC).

The FIT/PCM piece supplies the user interface that controls the card reader (or HID proximity reader), keyboard and display. The interface also controls and monitors pump activity.

The FIT/PCM software uses a version number that shows three pieces of information. The number has a format of "X.XXx."

- The first digit identifies the number of the FIT/PCM product and stays the same for the life of the product (the number for the PV100<sup>®</sup> is "2").
- The next two digits after the decimal point show a major revision to the product (the starting value is ".01").
- The last piece is a lower case alpha character that increases when a minor modification to the FIT/PCM occurs (the starting value is "a").

The FSC piece of software controls the daily operations of the PV100<sup>®</sup>. This software uses a version number that shows four pieces of information. The number has a format of "X.XX.XXx."

- The first digit identifies the number of the FSC software and stays the same for the life of the product (the number for the PV100<sup>®</sup> FSC is "3").



**NOTE:** The FSC uses battery backed-up RAM to save the vital configuration of the FSC (e.g., card file setup, pump configuration, transaction data, etc.) in the event of a power failure.

- The next two digits after the decimal point show that the card file configuration has been changed. An increase in this value shows that:

- **ALL** card file information such as PIN, Prompt and available pumps must be reconfigured.
  - Card Pump Totals are lost.
- The next two digits show when any other system configuration has changed. The pump configuration, stored transaction data and all saved data will be lost when this software update occurs. Reconfiguration of this information will be necessary.
- The last piece is a lowercase alpha character that increases when a minor modification to the FSC occurs (the starting value is “a”).



**NOTE:** If the card file number increases, the system configuration number can also change. This will show that a full-system cold start will occur. A complete reconfiguration of the FSC stored data will be necessary.

If only the system configuration number increases, a partial cold start of the FSC will occur. A reconfiguration of pump and system control settings will be necessary.

## 2.3 System Technical Specifications

This section details the technical specifications (i.e., dimensions, operating temperature range, power and wiring requirements) of the system and pump control.

### 2.3.1 Fuel Control System

PV100® Technical Specifications	
Cabinet Dimensions (H x W x D):	27 cm x 36 cm x 25 cm (10.75" x 14.25" x 9.75")
Pedestal Dimensions (H x W x D):	122 cm x 36 cm x 20 cm ( 48" x 14" x 8")
Power Requirements:	115/230 VAC, 50/60 Hz, 200 W Max
Operating Temperature Range	-40°C – +50°C (-40°F – +122°F )
Keypad Numeric/Function:	Standard
Magnetic Card Reader:	Optional
Proximity Card Reader:	Optional
Chipkey Reader:	Optional
Graphics Display:	Standard 15.2 cm (6") monochrome
Enclosure:	Powder Coated Steel
Pedestal:	Powder Coated Aluminum
Internal Fuel Site Controller:	Standard
Internal Pump Control:	Standard Mechanical - 2 hoses Optional - Mechanical or Electronic - 4 hoses



**NOTE:** Optional items may require additional cost

## 2.4 Pump Control

### 2.4.1 Mechanical Pump Control

**Mechanical Pump Control** is used when the dispensers connected to the system provide pulse inputs with in-use detection of handle switch or voltage sense.

To support this type of operation, one (1) or two (2) stand-alone relay boards, referred to as the "Pump Control Slave Module" or "PCM Slave" (OPW Part #: 20-4405), is mounted on the back wall of the PV100® enclosure, providing control for up to two (2) hoses. A second "PCM Slave" board can be added to control a total of four (4) hoses.

Mechanical Pump Control Specifications (PCM)	
Relay Contact Rating:	240-volts A; 20 A, 3.0 HP Max.
"In-Use" Detection:	Voltage Sense 120-240 VAC or Handle Switch
Pulser Type:	Single Channel
Pulser Input:	Mechanical (contact); Electronic (5-12 VDC)
Pulser Divide Rate:	Pulser Divide Rate:
Max. Pulse Speed:	6,000 Mechanical; 100,000 Electronic

## Section 3 Pre-Installation Information

The installation instructions in this manual are written for a typical installation. Due to the flexibility of the system and the unique nature of every site, it is not possible to show every potential installation scenario.

Local codes may dictate specific installation requirements. Installation is subject to approval by jurisdictional authorities at the site of installation. See Safety Precautions at the beginning of this manual.

If you have a QR code scanner/reader app for your smartphone you can scan this code to view the instructional video, **PV100® Installation and Startup**. If you are viewing this manual on a computer or tablet, simply click on the code.



### 3.1 Conduit/Wiring Requirements



**IMPORTANT:** All wiring and conduit runs must conform to the National Electric Code (NFPA No. 70), Code for Motor Fuel Dispensing Facilities and Repair Garages (NFPA No. 30A) and all national, state and local codes.

All wiring running to the system must be installed in threaded, rigid metal conduit and have the required sealoffs. AC and DC power wires can share conduit, provided they meet the Petro-Net™ wiring specified; otherwise AC and DC power wires must be installed in separate conduits.

#### 3.1.1 Conduit Sealing

Conduit entering the hazardous area must have a seal-off installed 18 inches (46 cm) above grade to prevent liquid or fumes from entering the area.

When running shielded cable through a seal-off, strip the cable jacket back so about three (3) inches (7.6 cm) of jacketed cable protrudes past each seal-off.



**WARNING:** Shielded cable is NOT vapor-tight! DO NOT damage the shield wire! Stripped section must be in the sealed-off area.





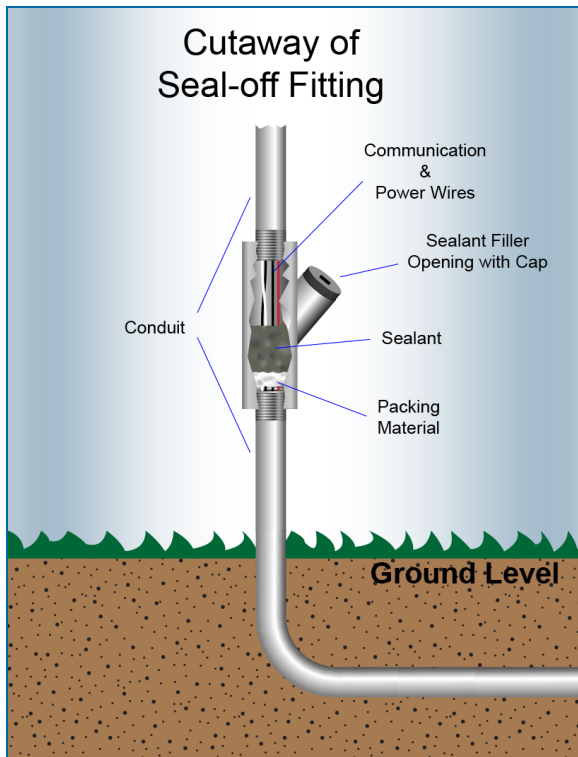

Conduit Sealing

### 3.1.2 Pedestal Conduits

All conduits in the PV100® pedestal should terminate at the conduit plate. A seal-off must be installed in these conduit runs. Install ½-inch or ¾-inch rigid steel conduits as applicable.



**IMPORTANT:** Any unused knockout holes that have been removed must be sealed in order to meet NEC code.

### 3.1.3 Grounding

The PV100® incorporates internal noise suppression circuitry. To ensure safety and proper operation of the equipment, all devices of the OPW system must be grounded.

A ground wire (preferably **Green**) must be connected between the device's ground terminal and the main electrical service panel. One earth ground connection is required per OPW device.



**CAUTION:** Do not rely on the conduit to provide ground connections.



### 3.1.4 PV100<sup>®</sup> Power Requirements

Power to the system must be supplied from a dedicated circuit breaker. No other equipment should be powered from this breaker, including the pumps that are being controlled. A separate conduit from the service panel directly to the PV100<sup>®</sup> is preferred, however, it is acceptable to share the conduit with dispenser wiring.

### 3.1.5 Pulser Wire

For mechanical pump installations, pulser wires must meet the pulser manufacturer's wire requirements if installed in separate conduit from the pump-control wires. If installed in the same conduit as the pump-control wires, then the wire must be UL-style #2567 or equivalent. You can order shielded pulser cable from OPW Part #: 12-1025 (two-conductor) or OPW Part #: 12-1026 (four-conductor).

## Section 4 System Installation

### 4.0.1 Typical Installation Overview



**WARNING:** Install your system a minimum of 18 inches (46 cm) from the nearest conventional or overhead pump or dispenser.

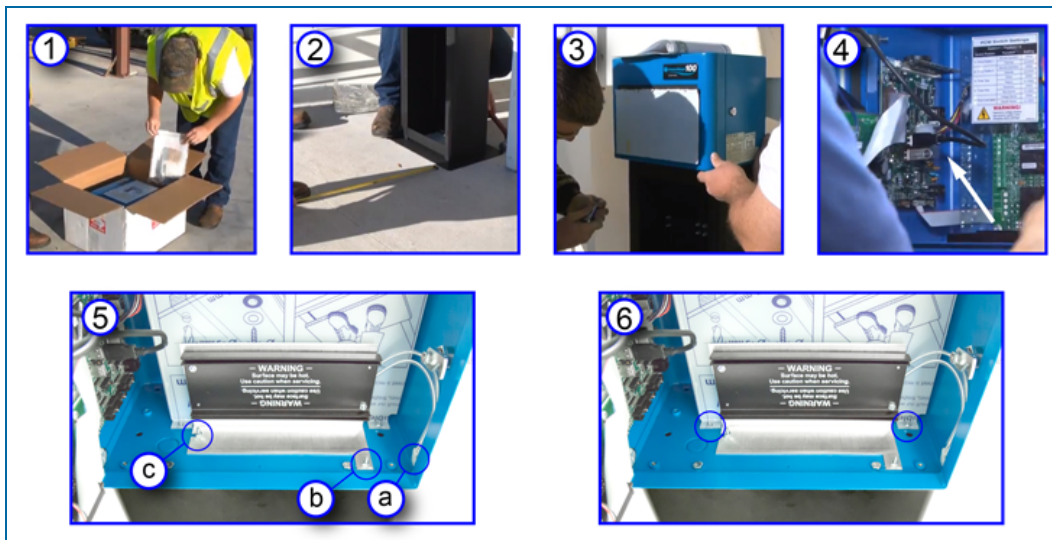

PV100® Installation

1. Unpack your new PV100® and inspect the contents for shipping damage. Make sure that all of the following are in the box:
  - A package of cards (if this will be a carded system)
  - Internal USB drive
  - Cabinet keys
  - Noise suppressors
  - Installation manual
2. Install the pedestal:
  - Square the baseplate where it will be mounted

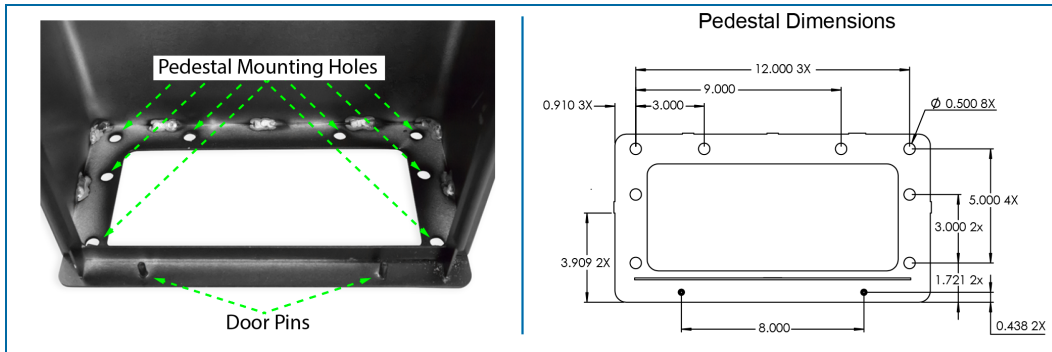

Pedestal Mounting Hole Locations and Dimensions

- Mark the four (4) most appropriate locations for the anchor bolts. There are eight (8) mounting holes (see the illustrations above).
- Drill the holes
- Anchor the pedestal using 3/8" anchor bolts



**IMPORTANT:** Use a type of anchor bolt that is appropriate for the material in which you will be drilling (e.g. concrete, asphalt etc.).

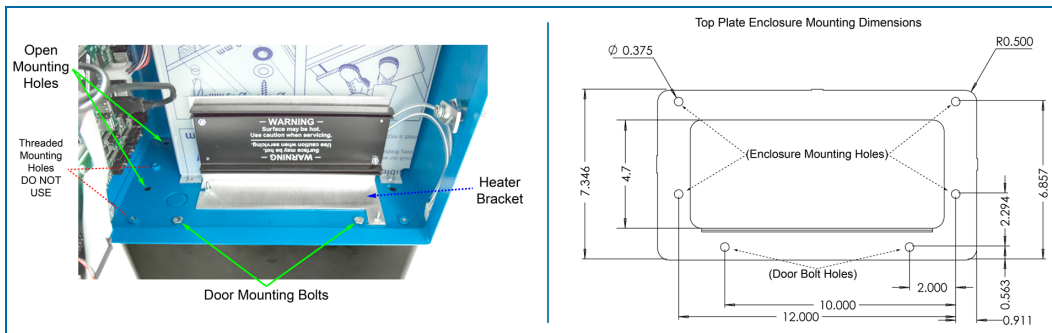

Enclosure Mounting to Pedestal

3. Use the provided mounting hardware to mount the PV100® enclosure to the pedestal. Align the provided gasket with the mounting holes of the pedestal top plate. Carefully position the enclosure in place so that the open mounting holes are aligned with the mounting holes of the pedestal. Insert the four (4) bolts and secure them using the provided washers and nuts.



**NOTE:** Make sure that the open holes are being used to mount the enclosure to maintain proper alignment of the enclosure and pedestal.

4. Disconnect the USB cable that runs from the door port to the main board.



**NOTICE:** The USB cable must be unplugged to avoid damage to the internal USB.

---

5. Remove the heater/bracket assembly.
    - a. Disconnect the heater cable.
    - b. Remove the hex nut from the screw in the right bracket “leg.” Set it aside where it will not be lost.
    - c. Loosen the left-side bracket hex nut enough to be able to slide the heater/bracket assembly out of the enclosure. Place the heater assembly aside in a safe place.
  6. Remove the two (2) hex nuts that hold the Lexan shield in place and remove the Lexan shield.
- 



**NOTICE:** Place the Lexan shield in a safe place where it will not get scratched.

---

If you have a QR code scanner/reader app for your smartphone you can scan this code to view the installation information section of the instructional video, **PV100® Installation and Startup**. If you are viewing this manual on a computer or tablet, simply click on the code.



## Section 5 Mechanical PCM Pump Control

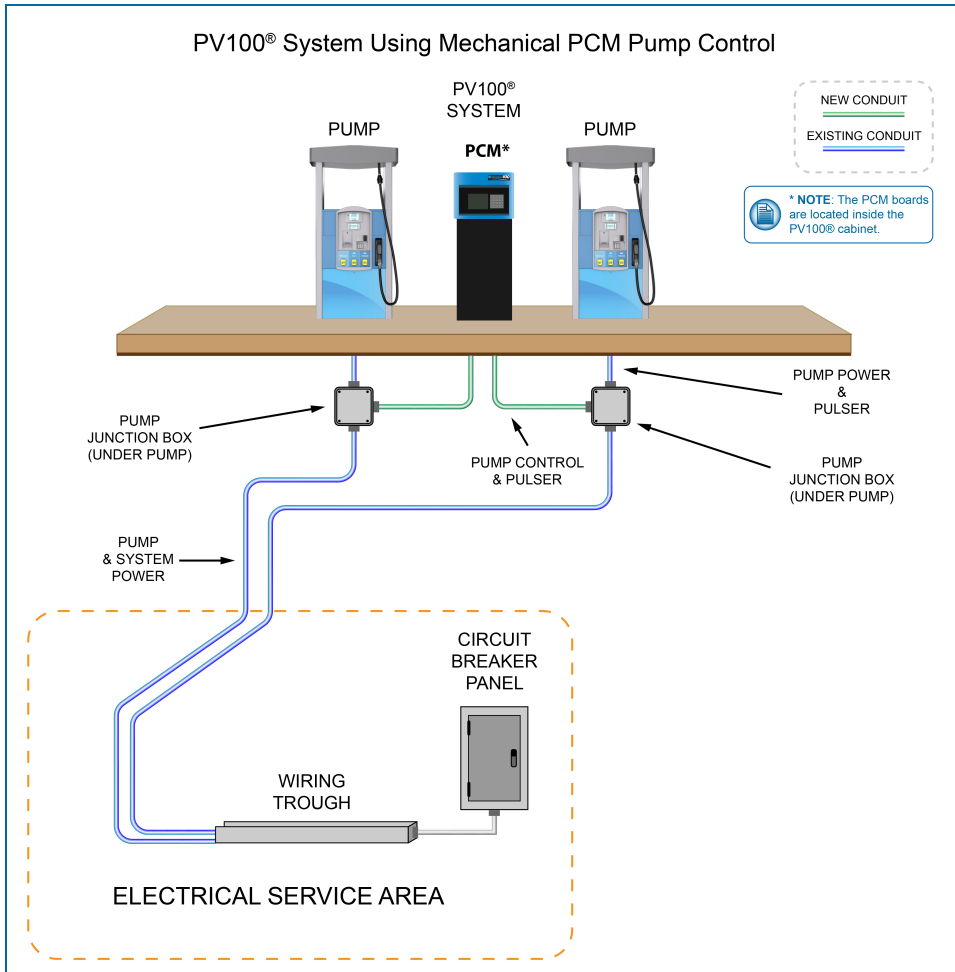

Typical Installation Overview with PCM Pump Control

### 5.1 Power Conduit Installation

Install conduit that runs from the main circuit breaker panel to the PV100®. This conduit will contain the Line, Neutral and Ground wires for the PV100®. This conduit can also contain pump power wires.

The power conduits must be stubbed from the seal-off to the bottom of the pedestal conduit plate.

Wires	Wire Requirements
Power (Hot, Neutral, Ground)	Three 93 wires (black, white, green) 600 V-Rated, Minimum #14-AWG- Oil & Gas Resistant, Wet Locations

## 5.2 PCM Conduit Installation

### 5.2.1 Pump Control/Pulser Conduit

Install conduit runs from the PV100® to each pump junction box. These will contain the line voltage pump control and low voltage pulser wires with the exceptions noted below.

Wires required are per fueling point. If conduit runs to a double-sided fuel pump, then the wire requirements listed below must be multiplied by two (x2).

Wires (per fueling point)	Wire Requirements
Pump Control	Six (6) wires (must meet pump manufacturer's specification for pump being controlled)
Pulser Wire	Two- or four-wire cable shielded – 600 V-Rated – Oil & Gas resistant, Wet Locations UL-style #2567



**NOTE:** Pump Pulser Wires may share Pump Control Conduit when they meet the specified requirements.

### 5.2.2 Pump Pulser Conduit

As an alternative to including the pulser wiring in the pump control conduit, a separate conduit for the pulser wire can be run.

This conduit is dedicated to bringing the pump pulser wires from the pump junction box to the terminal pedestal. Wires required are per fueling point. If conduit runs to a double-sided fuel pump, then wire requirements listed below must be multiplied by two (x2).

Wires (per fueling point)	Wire Requirements
Pulser Wire	Two- or four-wires. #18 AWG 600 V-Rated – Oil & Gas resistant, Wet Locations.



**NOTE:** Please refer to the typical installation diagram (mechanical) for pump control conduit wiring.

## 5.3 System Power Wiring

1. Pull three (3) #14-AWG wires (green [ground], black [line] and white [neutral]) from a dedicated circuit breaker to supply power to the PV100®.
2. Connect power (black) and neutral (white) wires to the power connection terminal block marked "LINE" (or "L") and "NEUTRAL" (or "N"). Connect the green ground wire to the terminal labeled "GROUND" (or "GND").

## 5.4 PCM Pump Dispenser Wiring

The PCM board is used for mechanical pump control.

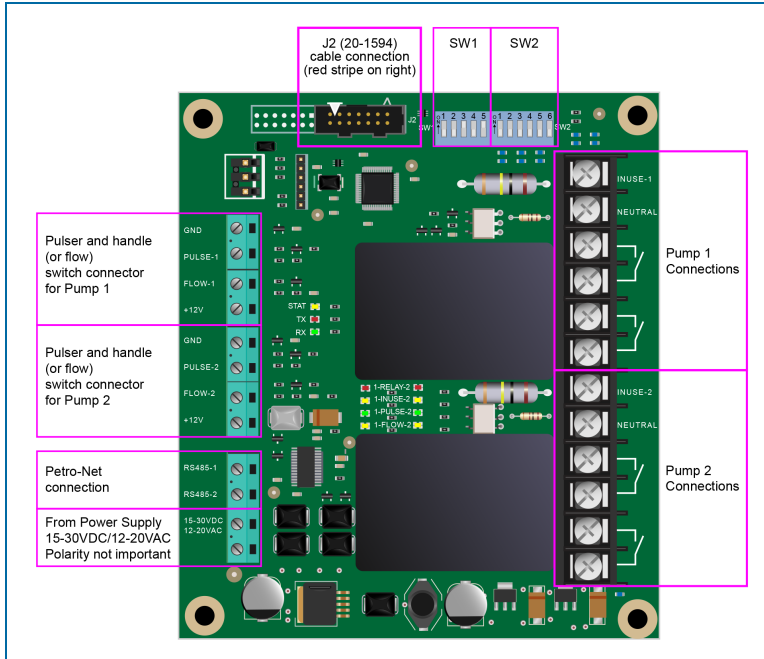

PCM Board Connections

The figure above shows the PCM board connections. The Low-voltage (pulser) connections are on the left side of the board and the High-voltage connections (hook, signal, neutral, S1 & S2) are on the right.

### 5.4.1 Pump/Dispenser Wiring

Follow the appropriate diagram below for the wiring of either a self-contained pump or a dispenser.

Low-voltage Connections	High-voltage Connections
GND – Ground for pulser and flow switch	In-Use – Feedback from solenoid or motor
Pulse - Pulser input	Neutral - Neutral return for In-Use signal
Flow - Flow switch or pump handle input	Relay Contacts - Reset Control
+12V – Supply for pulser	Relay Contacts - Motor Control



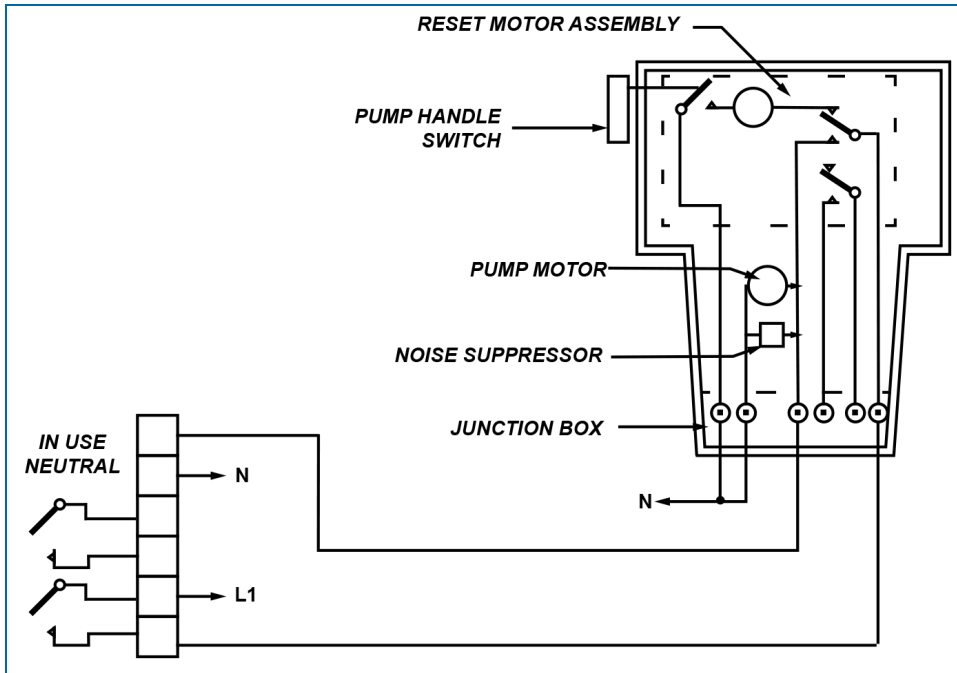

Typical Wiring for Self-Contained Pump with Power Reset

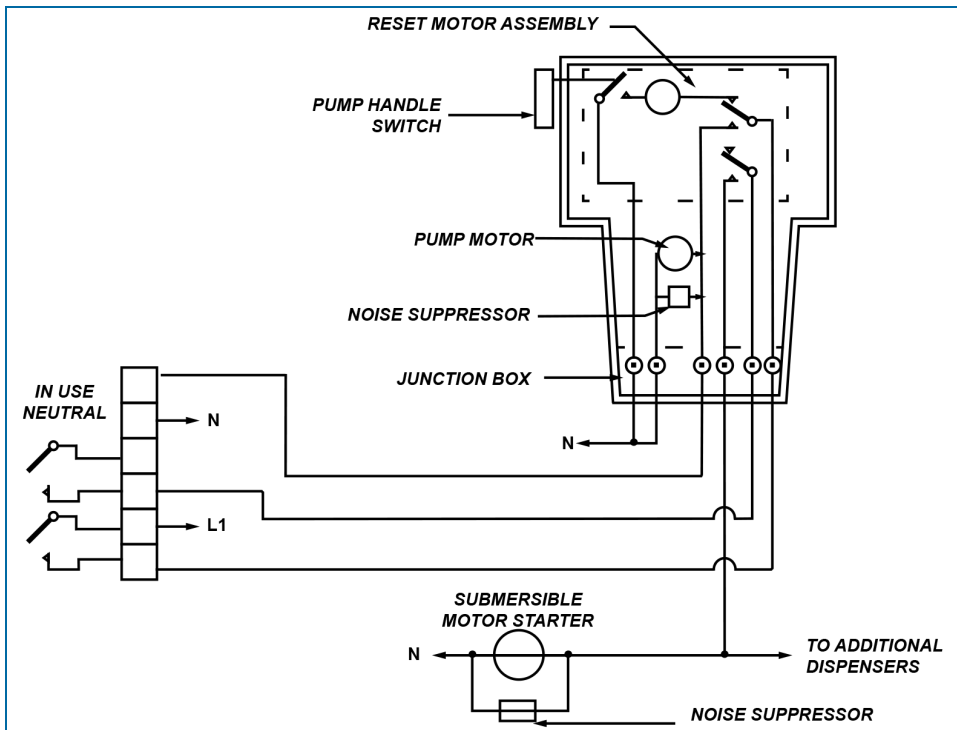

Typical Wiring for Dispenser with Power Reset

## 5.4.2 Pump/Dispenser Pulsar Wiring

There are two (2) types of pulsers:

- Passive (no voltage supplied)
- Active (voltage supplied)

The diagram below shows typical connections for both types of pulsers.



**NOTE:** Since the dip switch used to select pulser type controls both relay positions on the board, the two dispensers controlled by the PCM slave must be of the same type.

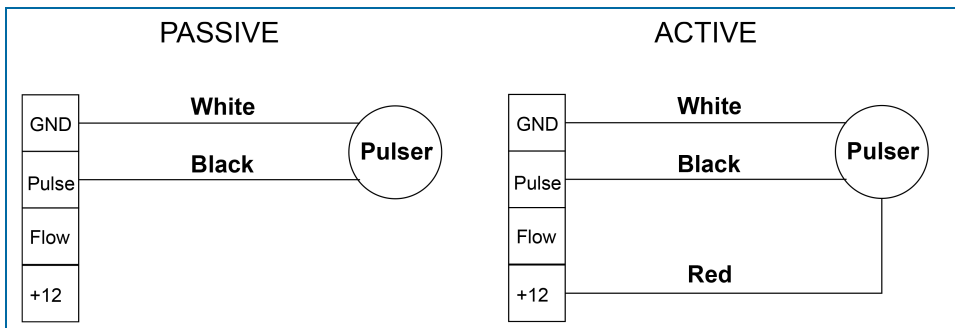

Pulsar Wiring

## 5.5 PCM Startup/Configuration

This section describes the procedure to configure the PCM board and to make sure that it is functional.

### 5.5.1 Configuration (DIP Switches)

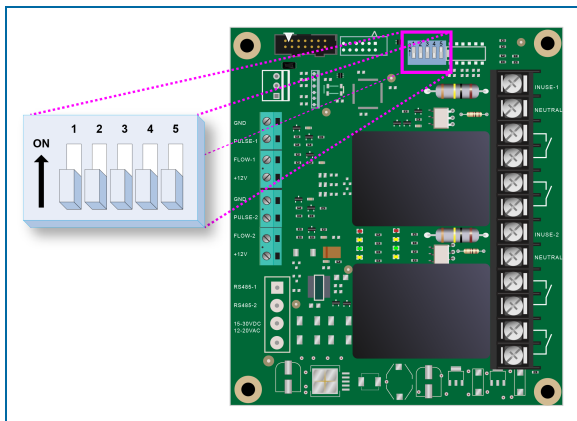

DIP Switch Block #1

**Operation Mode (SW 1, Position 1-2):** This setting will place the PCM into one of two operational states. Switch 1, position 1 is for relay position 1 of the PCM board; Switch 1, position 2 is for relay position 2.

- **Normal Operation:** By placing the switches in the “off” position, relays are energized by the fuel-site controller.
- **Manual Override:** By placing the switches in the “on” position, relays are energized by the PCM, which allows pumps to fuel without fuel-site controller control.

**Pulser Type (SW 1, Position 3):** This setting must match the electrical output of the pulser attached. The PCM supports two types of pulsers:

- **Active:** Pulsers supply a low-voltage signal to the PCM board.
- **Passive:** Pulsers either contain switch contacts or have “open collector” transistor outputs.



**NOTE:** This setting applies to the pulsers for both pump positions of the PCM; therefore, both pulsers must be of the same type.

**Pulser Filter (SW 1, Position 4):** Set to match the type of pulser attached. Mechanical pulsers cannot count as fast as electronic ones and will generate more electrical noise. Setting the Pulser Filter to “Mechanical” will filter the input signal.

- **Electronic:** Pulsers typically have shutter wheels and optical detectors.
- **Mechanical:** Pulsers have switches that open and close with each pulse.



**NOTE:** This setting applies to the pulsers for both pump positions of the PCM; therefore, both pulsers must be of the same type.

**In-Use Sense (SW 1, Position 5):** Set based on how the pump is wired to inform the PCM that the pump is authorized. The PCM is capable of two types of In-Use sense.

- **Voltage Sense:** The most common method, Voltage Sense uses a line-voltage return wire from the solenoid valve or pump motor wired to the “In Use” terminal on the high-voltage side of the PCM.
- **Handle Sense:** The alternate method, Handle Sense uses a contact closure input wired to the “Flow” terminal on the low-voltage side of the PCM.



**NOTE:** The setting applies to both pump positions of the PCM; therefore, both pumps' In-Use sense must be the same.

Switch #1, Positions 1-5				
Switch Position	Description	Relay Position	Description	Setting
1	Operational Mode	1	Normal Operation	OPEN
			Manual Override	CLOSED
2	Operational Mode	2	Normal Operation	OPEN
			Manual Override	CLOSED
3	Pulser Type	1 & 2	Active	OPEN
			Passive	CLOSED
4	Pulser Filter	1 & 2	Electronic	OPEN
			Mechanical	CLOSED
5	In-Use Sense	1 & 2	Voltage Sense	OPEN
			Handle Sense	CLOSED

## 5.5.2 PCM Testing



**WARNING: SHOCK HAZARD!** Once power is applied high voltages will exist in the system. Use caution when working inside the enclosure when the plastic shield is not in place



This test will make sure that the PCM is correctly wired to the pumps by using the **Manual Override** feature.

1. Apply power to the system.
2. Activate the bypass switch for the first relay on the PCM. You will hear the relay click "on." Check that the red "Relay" LED has turned on (see the figure below).



**NOTE:** Override is located in two (2) different locations.

3. Activate the pump or dispenser and watch the yellow "In Use" or "Handle/Flow" LED. It should light when the reset cycle is complete and the pump motor or solenoid valve is activated.
4. Dispense product and watch the green "Pulse" LED. It should flash as product is dispensed.
5. If equipped with a flow switch, the yellow "Flow" LED should light at the same time.
6. Turn "off" the bypass switch.

Repeat steps 1-6 for another relay.

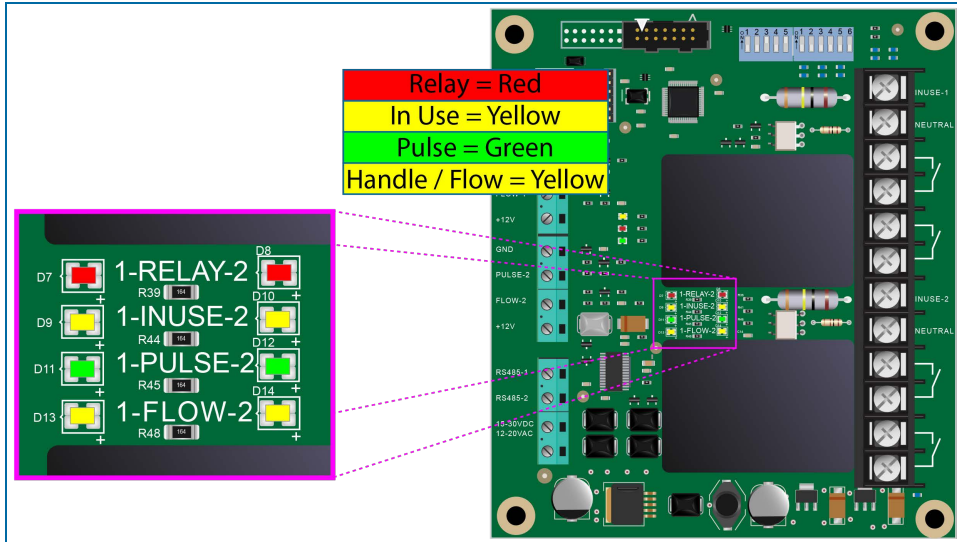

PCM Relay LEDs

When the test is complete, power off the PV100® and proceed to ["Complete the Installation" on page 30](#) to complete the installation.

If you have a QR code scanner/reader app for your smartphone you can scan this code to view the DIP switch configuration and testing segment of the instructional video, **PV100® Installation and Startup**. If you are viewing this manual on a computer or tablet, simply click on the code.



## Section 6 Complete the Installation



**NOTICE:** Double-check the wiring before applying power to the system components. Applying line (L) voltage to low-voltage inputs will damage the system.

Remove the yellow paper safety strip from the SIMM battery. If the system ever requires a cold-start, place a piece of paper or business card into the battery clip. A cold-start will clear all configuration settings except for transactions.

Now that the wiring has been installed and the system has been tested, the installation can be completed as follows:

1. Put the Lexan shield back in place and secure it with the two (2) hex nuts.
2. Reconnect the USB cable.
3. Slide the heater assembly back in place and secure it with the two (2) hex nuts.
4. Reconnect the heater cable.

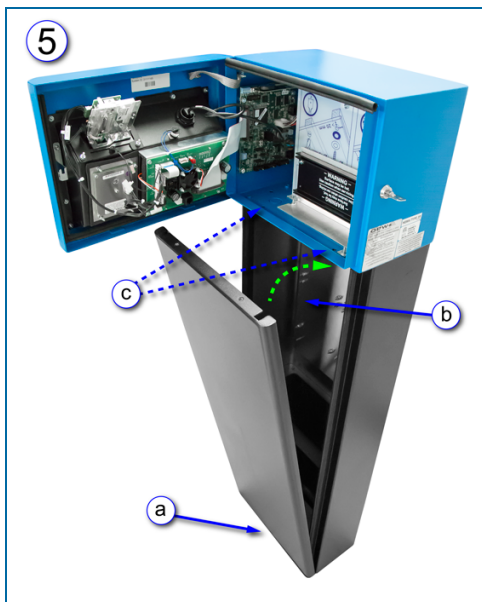

Pedestal Door Installation

5. Install the pedestal door.
  - a. Place the two (2) holes in the bottom of the door over the door pins in the front of the pedestal base.
  - b. Swing the top of the door into place as shown in the illustration.
  - c. Secure the door using the two (2) supplied hex bolts.

## Section 7 System Configuration

The configuration of the PV100<sup>®</sup> system is separated into two (2) parts: **Terminal Setup/Test Menu** and **Management Menu**.

- The **Terminal Setup/Test Menu** (see ["" below](#) for further instructions) allows for the adjustment of terminal system settings and peripheral devices.
- The **Management Menu** (see ["Management Menu" on page 36](#) for further instructions) consists of fuel site controller configuration options allowing you to manage card and pump processing conditions.

### 7.1 Terminal Setup/Test Menu

To access the **Terminal Setup/Test Menu**, open the door of the PV100<sup>®</sup> and flip DIP-switch bank #2, switch #1 (located on the main board, as shown in ["Main Board DIP Switch Bank #2 and Reset Button" on the next page](#)).

Next, hold the reset button for seven (7) seconds until the unit resets. The PV100<sup>®</sup> will restart automatically; the **Terminal Setup/Test Menu** will come into view.

The Terminal Setup/Test Menu consists of the following configuration options:

1. Display
2. Keypad
3. Reader
4. Tones
5. System Network Number
6. Petro-Net Setup
7. Miscellaneous
8. Pump Control
9. Software Update

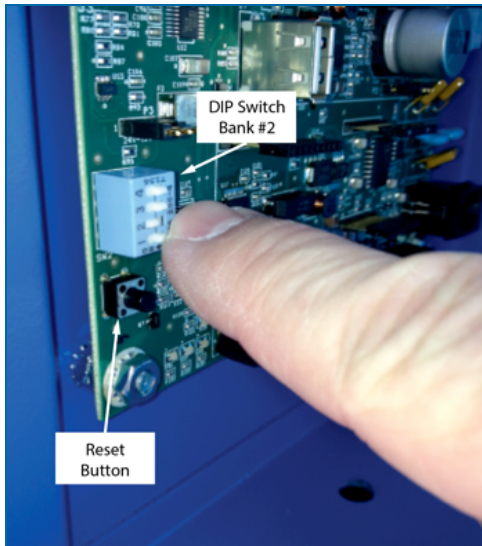

Main Board DIP Switch Bank #2 and Reset Button

## 7.1.1 Display Menu

Press '1' "Enter" to access the **Display Menu**. The **Display Menu** allows for access to the following configuration settings related to the information on the display screen, including the following:

- Mode
- Normal Screen Test
- Inverse Screen Test

**Mode:** "Normal" mode for the PV100® graphic display indicates that text and images will appear in dark color on a light background. "Inverse" mode indicates that text and images will appear in light color on a dark background. To choose between the two, press "F3". When the preferred display mode is shown, press "Enter".

**Normal Screen Test:** Choose this option to test the PV100® display screen in "Normal" mode.

To begin, press the menu item number that corresponds with **Normal Screen Test**. Various characters will run across the screen from left to right, in "Normal" mode, if the screen is functioning properly. To end the test, press "Enter".

**Inverse Screen Test:** Choose this option to test the PV100® display screen in "Inverse" mode.

Press the menu item number that corresponds with **Inverse Screen Test**. Various characters will run across the screen from left to right, in "Inverse" mode, if the screen is functioning properly. To end the test, press "Enter".

## 7.1.2 Keypad Menu

Press '2' "ENTER" to access the **Keypad Menu**. The Keypad Menu allows access to the keyboard test mode.

1. Numeric/Function Keypad Test



**Numeric/Function Keypad Test:** This test verifies that the keypad is working correctly and as configured. An empty table will come into view. Press any key of the keyboard to test. When pressed, each button will appear in its corresponding box in the table displayed on the display screen. Once each button is tested, press any button five (5) times to return to the menu.

### 7.1.3 Reader Menu

Press '3' "ENTER" to access the **Reader Menu**. The Reader Menu allows access to configurable settings for the card/key reader in-use by the system. The options available in the **Reader Menu** are as follows:

1. Select Reader
2. Test Readers

**Select Reader:** Select the specific card reader to be used with the PV100®. Press "F3" to cycle through the available options, which include Mag Reader (Track 2), Proximity Reader, Chipkey or Keyboard (no reader).

When setting this option to "Keyboard," no physical media (card, key, etc.) is required to access the system. In this mode, it is always suggested to require a PIN entry, to disable "cards" after 3 bad PIN entries and to invalidate unused "cards" ("[Proprietary Card File \(PCF\) Management](#)" on page 41). In keyboard mode, the insert card message will read "Enter."

**Reader Status:** This will test the functionality of the card/key reader. When prompted at the test screen, insert or present the card or key. If the card/key reader is functioning properly, the status will be displayed as "good" and the data on the card/key will be displayed.

Press "Clear" or "Enter," to test another card / key, or press "Enter" or "Clear" again to return to the **Reader Menu**.



**NOTE:** If Proximity Reader is selected, the system will display both the raw data read and the converted card number that will be passed as a valid card number.

### 7.1.4 Tones Menu

Press '4' "ENTER" to access the **Tones Menu**. The **Tones Menu** is comprised of setup and testing options for the sound tones played by the system, including the following:

1. Tone Sequence Test
2. Keypad Tone Setup
3. Prompt Tone Setup
4. Reader Tone Setup

**Tone Sequence Test:** This test verifies the tones of the PV100®. Press the number button that corresponds with the test then press "Enter". If functioning, a tone will be played to verify proper functionality.

**Keypad/Prompt/Reader Tone setup:**

1. **Tone Value:** Assigns the pitch of the tone played when a key is pressed, presented with a prompt, a receipt is printed, or the card reader is activated/used.
2. **Tone Duration:** Defines the duration of the tone played when a key is pressed, presented with a prompt, a receipt is printed, or the card reader is activated/used.



**NOTE:** A Keypad Tone Duration set to a value greater than 90 milliseconds is not recommended. This will cause keypad de-synchronization (pressing keys in succession will result in a delayed tone playback).

## 7.1.5 System Network Number Menu

The **System Network Number Menu** allows the user to set a number to identify your network.



**NOTE:** The default system network ID is 0000; the magnetic or proximity test card provided with your system is also default network ID 0000. Once the system has been tested, the installer should set the network ID to match the network ID coded on the cards that will be used with the system.

Press '5' "ENTER" to access the **System Network Number Menu**. There is one option within the **Network ID Menu**:

1. Network ID

**Network ID:** The Network ID is a security feature, and is also programmed on to each of the proprietary magnetic or proximity cards associated with the system. If the **Network ID** on the card does not match the **Network ID** in the system, fueling will not be allowed.

To set a **Network ID** number, type in the four-digit number that corresponds with the numbers encoded on the cards, then press "Enter."



**NOTE:** If your Network ID is unknown, use the Test Reader option (see 7.2.3 Reader Menu) to determine the first four digits encoded on your cards.

The network ID for proximity cards is restricted to a range of 0000-0255.

## 7.1.6 Petro-Net™ Setup Menu

Petro-Net™ setup is not available for the PV100®. Choosing this menu item will display the message "Petro-Net Setup is not available for the PV100®."

## 7.1.7 Miscellaneous Menu

The **Miscellaneous Menu** consists of miscellaneous tests and various restore options for the PV100®. Select the keyboard number that corresponds with the desired menu item number.

1. Lights Test
2. DIP Switch Test
3. RAM Test
4. USB Test
5. PCM Loopback Test

## 6. Restore Factory Defaults

**Lights Test:** Verifies the LED light above the keyboard and the card reader light. Press “F3” to turn the light on and off to verify that it is functioning properly.

**DIP Switch Test:** Displays the current positions of the DIP Switch, allowing confirmation that the DIP Switch is working properly. Press any key to return to the **Miscellaneous Menu**.

**RAM Loopback Test:** Performs an internal memory test of the system board.

**USB Test:** Tests both of the USB connections on the main board. To run this test, insert a USB key into the door-connector USB slot and one into the open USB port on the main board. If the USB Test fails, remove the door-connector USB cord from the USB port on the main board, then insert a USB key into both ports on the main board and re-run the test. If the test then passes, the fault lies in the USB connector cord between the door and main board.

**PCM Test:** Factory-performed test of the PCM board connections. If performed in the field, all tests will fail.



**NOTICE:** DO NOT run this test in the field while the pump relay board is connected. This can cause damage to the relay board.

**Restore Factory Defaults:** This will clear all configured parameters within the terminal side of the PV100<sup>®</sup> configuration and restore the default, pre-programmed settings. Press “F4” to confirm the restoration of factory defaults.



**NOTE:** Utilizing the Restore Factory Defaults option will clear all Terminal Configurations. Make sure to note your current Network ID before resetting; the one option that must be reset is the Network ID. Restore Factory Defaults should only be used when recommended by an OPW Technical Service representative.

## 7.1.8 Pump Control Menu

1. Pump Control
2. Pump Simulator Mode
3. Fixed Pump Number

**Pump Control:** This will disable pump control from within the terminal. It is recommended to only disable pump control if using an external pump-control module or internal DPC. Pressing “F4” will turn Pump Control “on”; pressing “F3” will turn it “off”. Once making the selection, press “Clear” to return to the **Pump Setup Menu**.

**Pump Simulator Mode:** This is used to test the PV100<sup>®</sup> system when pumps are not available. Never use **Pump Simulator Mode** unless installing or testing the PV100<sup>®</sup>.



**NOTE:** When operating in Pump Simulator Mode, pump and card totals will be incremented.

**Fixed Pump Number:** For a single pump system, setting the **Fixed Pump Number** to that of a configured pump as defined in the **Manager Menu** eliminates the “Enter Pump Number” prompt when fueling. Press “F3” or “F4” to turn **Fixed Pump Number** on, press “Enter” to save and exit.

## 7.1.9 Software Updates

The **Software Update Menu** consists of items that allow for firmware updates for the PV100<sup>®</sup> system from a USB Key. To obtain the proper firmware updates, contact OPW Technical Support at 1-877-OPW-TECH (877-679-8324) or visit <http://www.opwglobal.com>.

1. Program Application
2. Program FPGA
3. Program USB driver

**Program Application:** This option is a 2-step procedure to update the firmware for both the terminal and fuel-site controller. Once choosing this option, follow the instructions on the screen.



**NOTE:** Both software items (APPL\_S.ABS, APPL\_B.ABS) MUST be on the USB key before beginning the update procedure. Do not power off, unplug, or reset the PV100<sup>®</sup> during the update process.

**Program FPGA:** This option will update the PV100<sup>®</sup> circuit board firmware from the USB key. Once choosing this option, follow the instructions on the screen to proceed with the update.

**Program USB Driver:** This menu option updates the PV100<sup>®</sup> driver for the two (2) USB keys. Once choosing this option, follow the instructions on screen to proceed with the update.

## 7.2 Management Menu

The **Management Menu** consists of configurable settings for the management of the PV100<sup>®</sup> fuel-site controller. The following steps demonstrate the initial configuration of a **manager card**, and grants access to the PV100<sup>®</sup> management menu settings.

1. **Setting up manager cards:** With a new system, any two (2) cards can be assigned as manager cards. Swipe the first card that has been chosen as the manager card.
2. For first time configuration, configure the PIN to be associated with the manager card and press “Enter”. To do so, enter this PIN both times, as prompted.
3. When prompted to enter manager mode, choose “Yes” by pressing “F4”.



**NOTE:** If you are a distributor/installer, press «F1» to skip manager card configuration and enter Manager Mode directly.

4. To complete manager card configuration, follow the on-screen instructions.



**NOTE:** It is recommended to program a second manager card when prompted, in case the first is misplaced or destroyed. In the future, only the set PIN will be required at this point.

The card(s) chosen as the manager card(s) are also enabled for fueling.

The options available at the **Management Menu** are as follows:

1. Site Management
2. Pump Management
3. PCF Management
4. Clear Totals
5. Reporting

## 7.2.1 Site Management

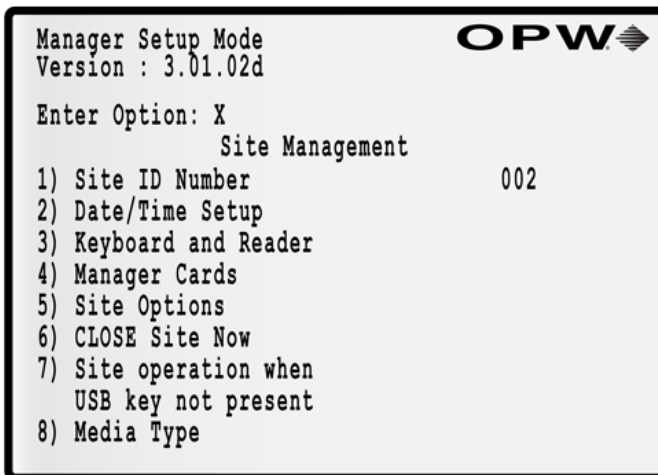

Site Management Menu

To access the **Site Management** menu, press the corresponding item number on the keypad, and then press “Enter”. The **Site Management** menu consists of the following items:

1. Site ID Number
2. Date/Time Setup
3. Keyboard and Reader
4. Manager Cards
5. Site Options
6. CLOSE / OPEN Site Now
7. Site Operation When USB Not Present
8. Media Type

**Site ID Number:** A three-digit number is used to identify the fueling site for reporting purposes. To set this number (default: 001), press the corresponding menu number on the keypad to access the setting and then press "Enter". Type the number to be associated with the fueling site (001-999) and then press "Enter" to save and exit or "Clear" to undo changes and exit.

**Date/Time Setup:** To access the Date/Time Setup menu item, press the corresponding menu item number on the keypad and then press "Enter". When chosen, the Date/Time Setup menu will display the following items. To access each item, press the corresponding menu number and then press "Enter:"

- **Date Format:** Select a format for the date display. To cycle through the available formats, press "F3". Once the desired format is displayed, press "Enter" to save and exit, or press "Clear" to undo changes and exit.
- **Time Format:** Select between a 12- and 24-hour-time format. Press "F3" to choose between the two aforementioned options, then press "Enter" to save and exit, or press "Clear" to undo changes and exit.
- **Open Time:** Enter a time of day when the fuel site will open for fueling. Type in the desired time in 24-hour format. Press "Enter" to save changes and exit, or "Clear" to undo changes and exit.
- **Close Time:** Enter a time when the fuel site will close for fueling. Type in the desired time in 24-hour format. Press "Enter" to save changes and exit, or "Clear" to undo changes and exit.



**NOTE:** When configuring "Open" and "Close" time for the system, you define when fueling is permitted by the system. If a user enters their card number, either by a card swipe or keyboard entry, the system will display, "System Closed", and return to the Insert Card screen. If a manager card number is presented, the system will operate as normal, allowing the manager card to fuel or enter the manager menus.

- **Light On:** Enter the time of day when the keyboard and Mag Reader lights will turn on. Type in the desired time in 24-hour format (hhmm). Press "Enter" to save changes and exit, or "Clear" to undo changes and exit.
- **Light Off:** Enter the time when the keyboard and Mag Reader lights will turn off. Type in the desired time in 24-hour format (hhmm). Press "Enter" to save changes and exit, or "Clear" to undo changes and exit.
- **Set Date/Time:** Set the current hours, day, date, month, and year for the internal clock of the system. Select Set Date/Time. Several options will come into view. Select a number that corresponds to one of the options and press "Enter."
  - **Set Time:** To set the current time on the internal clock, type the current time on the keyboard in 24-hour format (hhmm). Press "Enter" to save changes and exit, or "Clear" to undo changes and exit.
  - **Set Day:** To set the current day, cycle through the days of the week using the "F3" and "F4" buttons. When the current day shows, press "Enter" to save and exit, or "Clear" to undo changes and exit.
  - **Set Date:** To set the current date, use "F3" and "F4" to cycle through the dates (01-31) until the current date shows. Press "Enter" to save and exit, or "Clear" to undo changes and exit.
  - **Set Month:** To set the current month, use "F3" and "F4" to cycle through the months of the year, until the current month shows. Press "Enter" to save and exit, or "Clear" to undo changes and exit.

- **Set Year:** To set the current year, use “F3” and “F4” to select the current year. Press “Enter” to save and exit, or “Clear” to undo changes and exit.

**Keyboard and Reader:** The Keyboard and Reader item, when selected, displays the following keyboard-related configuration items:

- **Prompt Time-Out:** Determine the amount of time that prompts show until they go out of view.
- **Error Message Time-Out:** Determine the amount of time that error messages show until they go out of view.
- **Second Card Time-Out:** Used for the second card in Dual Card transactions. The default for the card reader timeout value is 15 seconds.

**Manager Cards:** The Manager Cards item displays the following card-related configuration items:

- **Reset Card 1:** Manager card 1 can be reconfigured.
- **Reset Card 2:** Manager card 2 can be reconfigured.
- **Force Manager PIN:** Ensures that if a proprietary card PIN is disabled (PCF), a manager card can always be forced to enter PIN. This is a security measure to protect **Manager Mode** entry.
- **Lock Reset:** A manager can re-configure the manager menu PIN in the event that the second Manager Card needs to be locked out for security reasons.

**Site Options:** This option displays the current purchased system options, SIMM serial number, and Electronic Serial Number (ESN). Also use this option to update purchased options through the USB door key.

- Insert a USB key with options (purchased separately) in the USB door port and press the “Update” function key.



**NOTE:** The Number of Cards and Number of Pumps fields on the Site Options screen can show up to four (4) pumps.

**CLOSE /OPEN Site now:** This option immediately changes the state of the system.

**Site Operation when USB not present:** This option can be used to control whether the site will shutdown if the internal USB key is not available to record transactions.

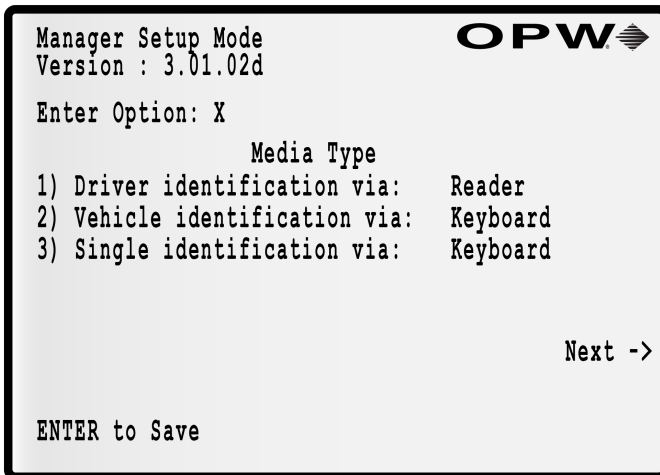

#### Media Type Menu

**Media Type:** This option allows the manager to set up input mode restrictions for all card types. The options are “Reader” and “Keyboard” and they are mutually exclusive. Push the F3 function key on the keyboard to toggle between Reader and Keyboard options.

Reader is the default for all three card types (Driver, Vehicle and Single). Driver and Vehicle card types are used with the ["Dual Card Security Feature" on page 49](#) factory-installed purchased option.

Card input is accepted through keyboard or physical reader in test mode if Keyboard is the specified input source for a card type and one of the reader types (magnetic, proximity or ChipKey) is enabled.



**NOTE:** If a Driver card is entered with the keyboard when Reader is specified and the Vehicle card is set up for Keyboard, the error message below will come into view.

"INVALID - MUST BE CARD/KEY"



**NOTE:** If the user tries to set up a Vehicle card as a Manager card, the error message below will come into view.

"Vehicle card cannot be used as manager card"

## 7.3 Pump Management

The **Pump Management** menu is used to edit configuration settings for the following items pertaining to the pump management. Select the menu item number that corresponds with “Pump Management” and press “Enter.”

- Select Pump Terminal
- Select Relay Position
- Configure Pump

**Select Pump Terminal:** This option is a non-selectable item, which defaults to 1.



**Select Relay Position:** This option is used to select the relay position associated with the pump to be configured (the value ranges from 1 to 4).

**Configure Pump:** Configure the parameters that follow in regard to the pump, divided between the categories "Configure Pump" and "Timeouts".

Configure Pump:

- **Pump Number:** Assign the number that is to be entered by the user when a fueling pump is selected. This value can be within the range of 1-4.
- **Pulse\ Count:** This value defaults to 100, but can be changed to accommodate pulse counts coming in from the pump, per unit.
- **Max Quantity:** Assign the maximum amount of fuel permitted in a single transaction. This value defaults to 25 gallons.
- **Ignore Handle:** Enable this setting to permit a user to remove the pump handle from the pump before swiping a card. It is not recommended to enable this setting in most scenarios.
- **Set Totalizer:** Set a value at which the totalizer is to be displayed on the pump. This is an incremental value, and it can be reset with the use of the manager card.
- **Pump Sentry:** Enable this setting to tell the PV100® that three (3) consecutive, zero-quantity transactions indicate a bad pulser, and in this event the pump will be disabled. This acts as a security measure to prevent theft or loss of fuel. This setting must be cleared from the Configure Pump Menu once the issue is fixed.

Timeouts:

- **Handle:** This value indicates the time (seconds) that the pump will remain active without a handle sense. Select from a range of 1-999 seconds.
- **First Pulse:** This value indicates the time (seconds) that the pump will remain active after sensing the handle before 1st pulse. Select from a range of 1-999 seconds.
- **Missing Pulse:** This value indicates the time (seconds) that the pump remains active without pulses having been detected. Select from a range of 1-999 seconds.
- **Total Transaction:** This value indicates the time (minutes) that fueling is allowed. This time period begins when the handle is sensed.

## 7.4 Proprietary Card File (PCF) Management

The **Proprietary Card File (PCF) Management** menu allows for the management of the card data associated with the PV100®, and is used for single-card systems only. To access the PCF Management Menu, press the number on the keyboard that corresponds with the menu item number for "PCF Management". The menu consists of the following items:

- Setup PCF
- View Pump Restrictions
- View Prompted Cards

**Setup PCF:** Configure the settings for pump restrictions and setup the PIN configurations for the PV100®. Within the **Setup PCF Menu**, the following options are available:

- Pump Restriction Setup:

- Select Card:** Determine one (1) specific card for which you will be **Selecting Allowed Pumps**.
- Select Card Range:** Determine a range of cards (example: 10-50) for which you will be **Selecting Allowed Pumps**.
- Select Allowed Pumps:** This option will display all configured pumps and permit the pumps that are selected above to be enabled or disabled.

```

Manager Setup Mode                               OPW
Version : 3.01.02d

                                     Yes →
      Pump Restriction Setup
1> Select Card Range      0001
2> Select Card Range      No →
3> Select Allowed Pumps

      Pump 1  yes
      Pump 2  yes
      Pump 3  yes
      Pump 4  yes
                                     Next →

ENTER to save
Manager cards will not be changed
    
```

```

Manager Setup Mode                               OPW
Version : 3.01.02d

                                     Yes →
      Pump Restriction Setup
1> Select Card Range      0001
2> Select Card Range      No →
3> Select Allowed Pumps

      Pump 1  yes
      Pump 2  yes
                                     Next →

ENTER to save
Manager cards will not be changed
    
```

Pump Restrictions - 4 Pump Setup & 2 Pump Setup

```

Manager Setup Mode                               OPW
Version : 3.01.02d

Cards      1      Pumps      4      -50 →
           2      3
0001      yes  yes  yes  yes
0002      yes  yes  yes  yes
0003      yes  yes  yes  yes
0004      yes  yes  yes  yes
0005      yes  yes  yes  yes
0006      yes  yes  yes  yes
0007      yes  yes  yes  yes
0008      yes  yes  yes  yes
0009      yes  yes  yes  yes
0010      yes  yes  yes  yes
                                     +50 →
    
```

```

Manager Setup Mode                               OPW
Version : 3.01.02d

Cards      Pumps      2      -50 →
           1
0001      yes  yes
0002      yes  yes
0003      yes  yes
0004      yes  yes
0005      yes  yes
0006      yes  yes
0007      yes  yes
0008      yes  yes
0009      yes  yes
0010      yes  yes
                                     +50 →
    
```

Allowed Pumps - 4 Pump Setup & 2 Pump Setup

- PIN Setup:**
  - Disable PIN Entry:** This option is used to prevent PIN prompts required for cards. It is not recommended to disable PIN entry if **Keyboard Entry** is enabled.
  - Set Specific PIN:** Each PCF PIN can be set, card-by-card. Use this option to eliminate the configurable option (Manual Reset, Disable Pumps). Enter 0 to have each PIN user-selectable.
  - All User Selectable:** This option resets all cards, including manager cards, to user-selectable. All users will be required to reselect a PIN on the next swipe of their card.

- **Card Invalid After 3 Bad Entries:** When this option is enabled, the PV100® will lock cards from use after three (3) incorrect PIN entries for a single swipe. When a card is locked, the user PIN must be reset using the **Set Specific PIN** menu option.
- Configure Prompt 1:
  - **Select Card:** Determines one (1) specific card for which you will be enabling Prompt 1.
  - **Select Card Range:** Determine a range of cards (example: 10-50) for which you will be enabling Prompt 1.
  - **Select Prompt:** This option permits the user to set the prompt presented. Use “F3” and “F4” to cycle through the prompts. Press **Enter** to save and exit, or **Clear** to undo changes and exit. The available prompts for selection are:
    - ◆ Enter Misc. 1
    - ◆ Enter Misc. 2
    - ◆ Enter Hub
    - ◆ Enter Trip #
    - ◆ Enter Trailer #
    - ◆ Enter Account #
    - ◆ Enter Odometer
    - ◆ Enter P.O.
    - ◆ Enter Driver I.D.
    - ◆ Enter Vehicle #
- **Enable/Disable Prompt:** This option permits enabling or disabling of Prompt 1 based on the previously selected card(s).
- **View Pump Restrictions:** The **View Pump Restrictions** menu item displays a list of all programmed pump restrictions, which can be scrolled by using the “F1”, “F2”, “F3”, and “F4” buttons.
- **View Prompted Cards:** The **View Prompted Cards** menu item displays a list of all allowed cards and shows whether or not they will be presented with Prompt 1. They can be scrolled through using the “F1”, “F2”, “F3”, and “F4” buttons.

As shown in **"Reporting" on the next page** "Transactions to USB," the collected prompt is provided in the last column of the PV100TRN.CSV file. The label of this column is written to reflect that of the prompt presented to the user. Whenever enabling the additional prompt or modifying the existing prompt, it is suggested to always transfer transactions from the internal recording key to the door key before proceeding with fueling. This will ensure that the name presented in the transaction file matches the value of the collected transactions.

### 7.4.1 Clearing Totals

The **Clear Totals** menu permits the removal of all totals currently stored on the FSC for the FIT. To delete totals, choose the number corresponding with the desired category for which to delete the totals, and then press “Enter”. To confirm the deletion, press “F3”. The categories for deletion are as follows:

- All Cards

- All Cards and Pumps
- Single Card
- Single Pump (can accept a value in the range 1 - 4)
- Bypass Totals

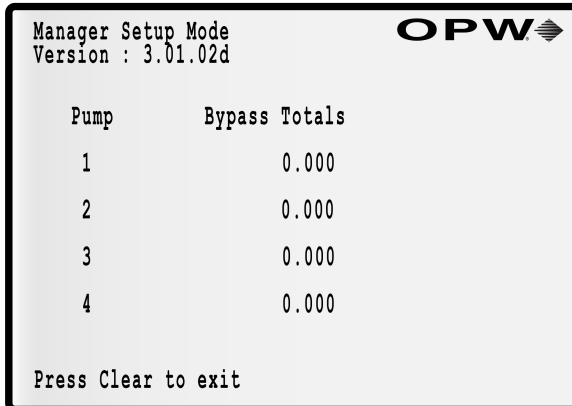

Pump	Bypass Totals
1	0.000
2	0.000
3	0.000
4	0.000

Press Clear to exit

Bypass Totals Screen

## 7.4.2 Reporting

The **Reporting** menu permits a user to view reports for the various functions of the PV100®, divided as follows:

- View Pump Totals
- View Card Totals
- View Bypass Totals
- Pump Totals to USB
- Card Totals to USB
- Transactions to USB

**View Pump Totals:** To show the totals for each pump, press the corresponding menu number on the keypad and then "Enter".

Manager Setup Mode		OPW	
Version : 3.01.02d			
Pump	Total	Totalizer	
1	0.000	0.000	
2	0.000	0.000	
3	0.000	0.000	
4	0.000	0.000	
Press Clear to exit			

View Pump Totals

**View Card Totals:** To show the totals for cards, press the corresponding menu number on the keypad and then "Enter."

Manager Setup Mode		OPW	
Version : 3.01.02d			
Pump 1 & 3	Pump 2 & 4		
0001	0.000	0.000	-50 →
	0.000	0.000	-5 →
0002	0.000	0.000	
	0.000	0.000	
0003	0.000	0.000	+5 →
	0.000	0.000	
0004	0.000	0.000	
	0.000	0.000	
0005	0.000	0.000	+50 →
	0.000	0.000	

Manager Setup Mode		OPW	
Version : 3.01.02d			
Pump 1	Pump 2		
0001	0.000	0.000	-50 →
0002	0.000	0.000	-10 →
0003	0.000	0.000	
0004	0.000	0.000	
0005	0.000	0.000	+10 →
0006	0.000	0.000	
0007	0.000	0.000	
0008	0.000	0.000	
0009	0.000	0.000	+50 →
0010	0.000	0.000	

View Card Totals 4-Pump Support and 2-Pump Support



**NOTE:** The 4-Pump site configuration will show five (5) cards with the card totals for Pump 1 and 2 showing on the top lines and totals for 3 and 4 on the bottom lines. See the illustration below.

<p>Totals for Pump 1 &amp; 2 are on the top line. Totals for Pump 3 &amp; 4 are on the bottom line for each Card listed.</p>		Pump 1 & 3		Pump 2 & 4	
	0001	Pump 1	0.000	Pump 2	0.000
		Pump 3	0.000	Pump 4	0.000
	0002	Pump 1	0.000	Pump 2	0.000
		Pump 3	0.000	Pump 4	0.000
	0003	Pump 1	0.000	Pump 2	0.000
		Pump 3	0.000	Pump 4	0.000
	0004	Pump 1	0.000	Pump 2	0.000
		Pump 3	0.000	Pump 4	0.000
	0005	Pump 1	0.000	Pump 2	0.000
		Pump 3	0.000	Pump 4	0.000

View Card Totals 4-Pump Support

**View Bypass Totals:** To show all transactions that occurred while the pumps were in software-controlled bypass (see Appendix A), press the corresponding menu number on the keypad and press “Enter”.

To perform the operations that follow, first place a USB key/thumb drive into the USB receptacle mounted above the PV100® display.

**Pump Totals to USB:** The system will create a CSV-formatted file with a file name of P\_YYMMDD.CSV where YYMMDD represents the date at which the file was created. If this option is selected a second time on the same day, any existing file with that date will be over-written.

	A	B	C	D
1	Pump #	Totals	Totalizer	12:03 PM
2	1	1273.06	16549.78	
3	2	1181.95	15365.35	
4	3	1262.16	16532.12	
5	4	1196.22	15422.32	

Example of Pump Totals

**Card Totals to USB:** The system will create a CSV-formatted file with a file name of C\_YYMMDD.CSV where YYMMDD represents the date at which the file was created. If this option is selected a second time on the same day, any existing file with that date will be over-written.



**NOTE:** The time stamps in these examples show the time at which the files were generated.

	A	B	C	D	E	F
1	Card #	Pump # 1	Pump # 2	Pump # 3	Pump # 4	12:04 PM
2	1	0	0	0	0	
3	2	0	0	0	0	
4	3	348.33	35.19	0	0	
5	4	4.05	0	22.77	0	
6	5	72.07	73.35	28.52	37.75	
7	6	0	0	0	0	
8	7	0	0	0	0	
9	8	8.12	0	0	188.3	
10	9	139.93	2.47	0	0	
11	10	35.53	630.91	47.89	168.66	
12	11	287.13	24.87	82.78	97.96	
13	12	0	0	0	0	
14	13	0	0	0	0	
15	14	0	0	0	0	
16	15	287.13	24.87	27.7	12.52	
17	16	25.6	212.48	22.22	87.09	
18	17	0	0	0	0	
19	18	0	0	0	0	
20	19	0	0	0	0	
21	20	225.68	58.07	31.21	68.22	
22						
23	49	0	0	0	0	
24	50	0	0	0	0	
25	51	0	0	0	0	
26	0	85.51	0	0	0	

Example of Card Totals

**Transactions to USB (optional):** If this purchasable option is enabled, individual transactions stored on the internal USB key will be transferred to the external USB key in the file PV100TRN.CSV.



**NOTE:** See Appendix B for transaction termination codes.

	A	B	C	D	E	F	G	H	I	J
1	Site ID	Termination	Start Time	End Time	Date	Trans #	Card #	Pump #	Quantity	Misc 1
2	1	e	0:00	12:02 AM	3/29/16	3	8			
3	1	l	12:02 AM	12:02 AM	3/29/16	4	10	1	0.51	
4	1	l	12:02 AM	12:02 AM	3/29/16	5	8	2	1.21	123456
5	1	l	12:02 AM	12:03 AM	3/29/16	6	10	2	0.76	
6	1	l	12:03 AM	12:03 AM	3/29/16	7	10	1	0.71	
7	1	l	12:03 AM	12:03 AM	3/29/16	8	8	3	1.12	4444
8	1	l	12:03 AM	12:03 AM	3/29/16	9	8	4	0.65	54321

Example of Transactions

For further programming information on both non-card (keyboard only) and carded systems from the instructional video, **PV100® Installation and Startup**, simply scan or click the following QR Codes. The instructional video can also be found at [www.YouTube.com](http://www.YouTube.com) by entering the search word "OPWGlobal".



[Program a Non-Card, Keyboard Only System](#)



[Program a Carded System](#)



## 7.5 Dual Card Security Feature

The Dual Card security feature requires both Driver and Vehicle cards to be validated to successfully authorize a pump to dispense fuel. This adds one more layer of security in the fueling process.

The PV100 can be set up for one (1) of four (4) input restriction configurations (see "Site Management" on page 37 - **Media Type** menu option for information on input restrictions):

Configuration	Driver ID Input	Vehicle ID Input
1	Card/Key Reader	Card/Key Reader
2	Card/Key Reader	Keyed-in Manual Entry
3	Keyed-in Manual Entry	Card/Key Reader
4	Keyed-in Manual Entry	Keyed-in Manual Entry

### Card Configuration Menu

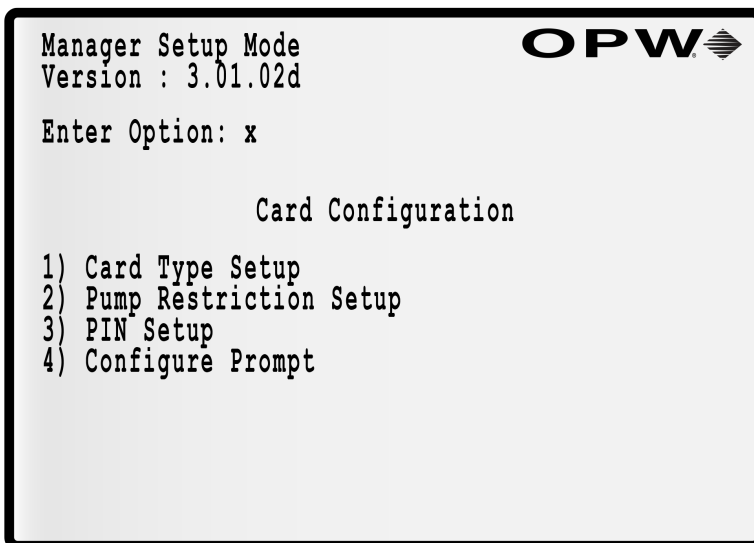

Card Configuration Menu

To configure cards for the Dual Card security feature select the Card Type Setup option from the Card Configuration menu.

### Card Type Setup Screen

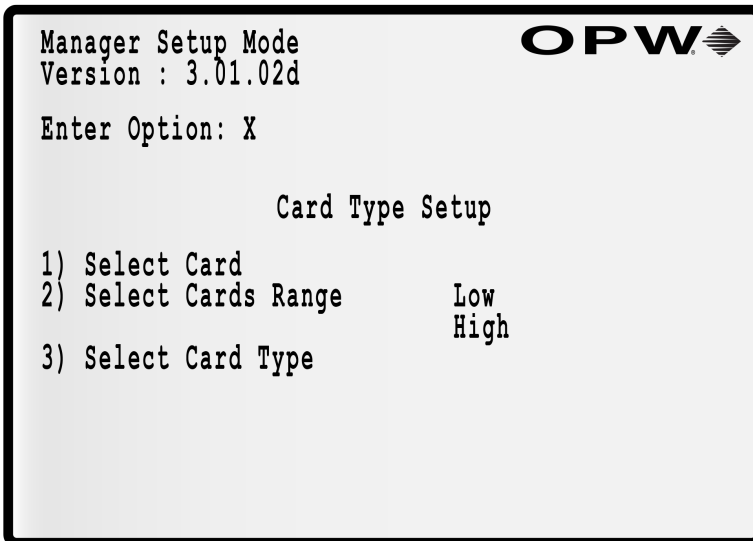

Manager Setup Mode **OPW**   
Version : 3.01.02d  
Enter Option: X

Card Type Setup

- 1) Select Card
- 2) Select Cards Range           Low  
  High
- 3) Select Card Type

#### Card Type Setup

The **Card Type Setup** screen is where the Card Type is specified for a range of cards and an individual card number. The available types are Driver, Vehicle and Single.

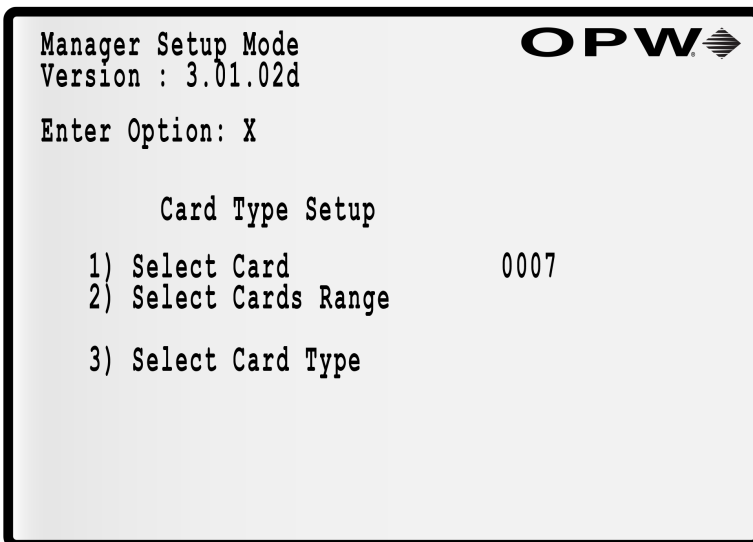

Manager Setup Mode **OPW**   
Version : 3.01.02d  
Enter Option: X

Card Type Setup

- 1) Select Card                   0007
- 2) Select Cards Range
- 3) Select Card Type

1. Select a card number.

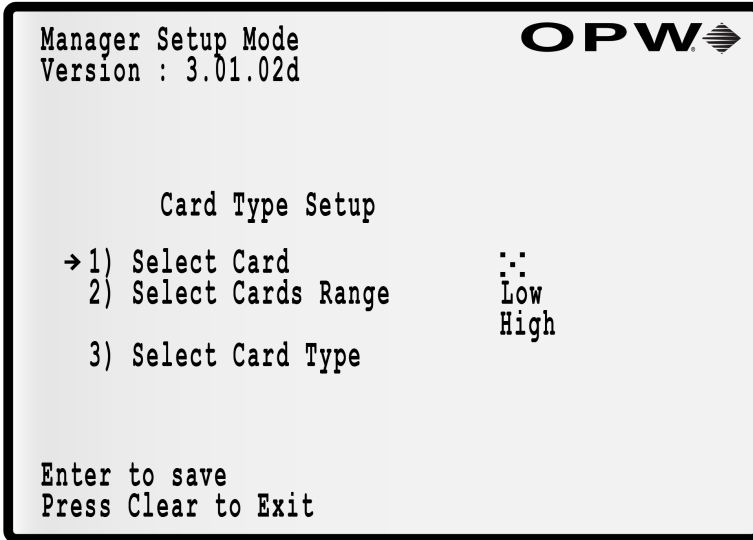

2. Set the Low and High values.



**NOTE:** A range will override another if the range that is entered overlaps the range of another Card Type.

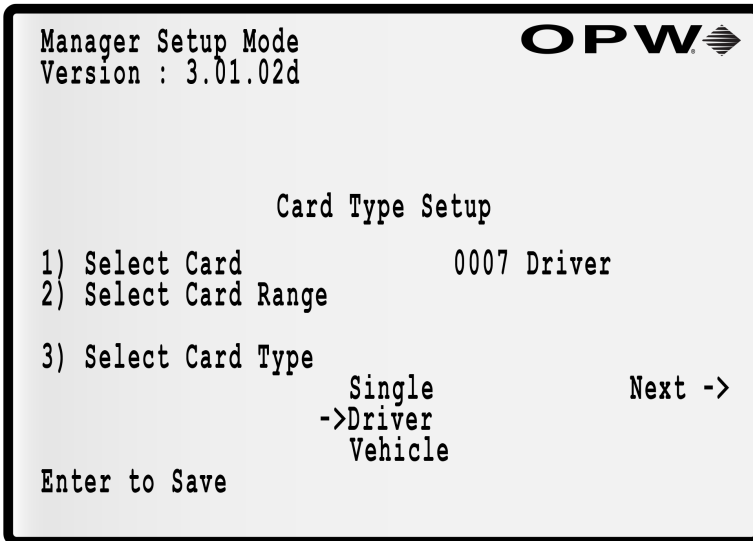

3. Push the F3 function key to show the types. Push F3 again and again to scroll through and select the applicable types (Driver, Vehicle and Single). Push **Enter** to save the selection.



**NOTE:** If the user tries to select Vehicle for a specified Manager card the error message below will come into view:

"Selected card is Manager card and its type cannot be vehicle"



**NOTE:** If the user tries to set a range that contains a Manager card the error message below will come into view:

"Range contains Manager card and its type cannot be vehicle"

### Set Specific PIN Screen

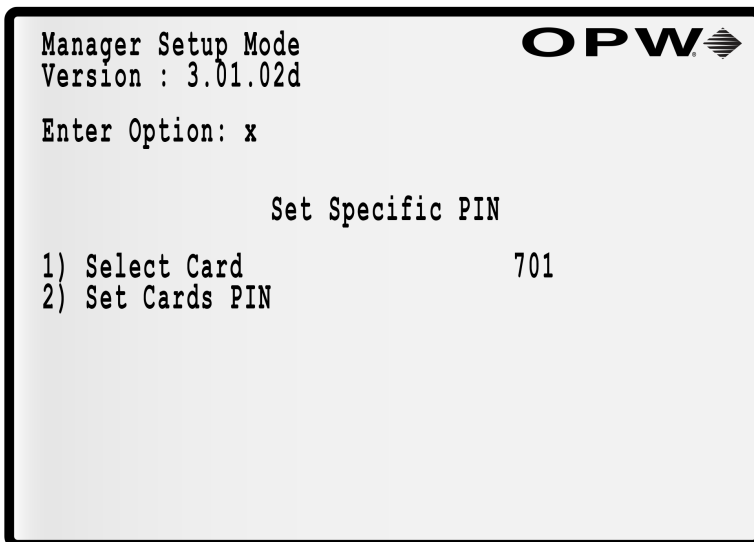

Set Specific PIN

Before a PIN can be set the Card Type and Range must be set up (see above).



**NOTE:** If a Vehicle card is selected the error message below will come into view:

"PIN is not valid for Vehicle card"

**View Allowed Pumps**

Manager Setup Mode		OPW 				
Version : 3.01.02d						
Cards	T	1	2	3	4	
0001	D	yes	yes	yes	yes	-50 →
0002	D	yes	yes	yes	yes	-10 →
0003	D	yes	yes	yes	yes	
0004	D	yes	yes	yes	yes	
0005	V	yes	yes	yes	yes	+10 →
0006	V	yes	yes	yes	yes	
0007	V	yes	yes	yes	yes	
0008	S	yes	yes	yes	yes	
0009	S	yes	yes	yes	yes	+50 →
0010	S	yes	yes	yes	yes	

View Allowed Pumps (4 Pump)

When the Dual Card security feature is enabled, the View Allowed Pumps screen in Proprietary Card File (PCF) Management will show the Card Type next to each card number listed.

**View Card Totals**

Manager Setup Mode		OPW 				
Version : 3.01.02d						
Cards		Pump 1 & 3	Pump 2 & 4			
0001	D	0.000	0.000		-50 →	
		0.000	0.000		-5	
0002	D	0.000	0.000			
		0.000	0.000		+5	
0003	V	0.000	0.000			
		0.000	0.000			
0004	V	0.000	0.000			
		0.000	0.000			
0005	S	0.000	0.000		+50	
		0.000	0.000			

View Card Totals (4 Pump)

When the Dual Card security feature is enabled, the View Card Totals screen in Reporting will show the Card Type next to each card number listed.

### Card Totals Report

	A	B	C	D	E	F	G
1	Card #	type	Pump #1	Pump #2	Pump #3	Pump #4	12:04 PM
2	1	S	0	0	0	0	
3	1	S	348.33	0	35.19	0	
4	1	D	4.05	73	24.87	0	
5	1	D	72.07	67	8.12	212.48	
6	1	D	0	0	0	0	
7	1	V	348.33	0	35.19	0	
8	1	V	4.05	73	24.87	0	
9	1	V	72.07	67	8.12	212.48	
10	1	S	848.33	0	55.19	0	
11							
12	998	D	255.68	54	0	35	
13	999	V	57	52	55	35	
14	1000	V	57	100.5	0	0	
15	0	V	85.51	0	0	0	

Card Totals Report for Dual Card

When the Dual Card security feature is enabled, the Card Totals to USB report will show Card Type information. Transaction amounts will be added to both the Driver and Vehicle card totals.

### Transactions Report

	A	B	C	D	E	F	G	H	I	J	K
1	Site ID	Termination	Start Time	End Time	Date	Trans #	Driver/Single Card #	Vehicle Card#	Pump #	Quantity	Misc 1
2	1	e	0:00	0:00	2/26/16	1	8	0	1	0.51	
3	1	l	12:02 AM	12:02 AM	2/26/16	2	999	30	2	1.21	123456
4	1	l	12:02 AM	12:02 AM	2/26/16	3	800	30	2	0.76	
5	1	l	12:02 AM	12:02 AM	2/26/16	4	10	3	3	0.71	
6	1	l	12:03 AM	12:03 AM	2/26/16	5	500	100	3	1.12	
7	1	l	12:03 AM	12:03 AM	2/26/16	6	8	0	4	0.65	4444
8	1	l	12:03 AM	12:03 AM	2/26/16	7	6	0	4	1.09	54321
9	1	z	12:03 AM	12:03 AM	2/26/16	7	15	0	0	1.09	54321

Transactions Report for Dual Card

When the Dual Card security feature is enabled, the Transactions to USB report will show Card Type information. The report will also include the manager card transaction.



**NOTE:** The Manager mode transaction will show 'z' in the Termination column and "0" (zero) in the Pump # column (this is to be used when a manager inserts a card to run reports, etc. but not turn on a pump and not miss a transaction number in the report).

## Section 8 System Maintenance

Though the PV100® card systems are designed for years of trouble-free use, please perform the following routine maintenance as indicated below to maximize the system's service life.

**Cabinet and Door:** Wipe down terminals with warm water, a mild detergent (dish soap) and a non-abrasive cloth as needed. DO NOT power-wash or use a garden hose to rinse off the system! Standard automobile wax may be used to protect the finish of the terminal's cabinet and pedestal.

**Display:** Do not use harsh detergents or any type of petroleum-based cleanser on the display.

- Recommended Cleansers: AR Kleener, Diamond Glaze Anti-Reflective Cleaner.

**Keypad:** Wipe down terminals with warm water, a mild detergent (dish soap) and a non-abrasive cloth as needed. If Keypad becomes damaged, replace.

**Door Locks:** Lubricate door locks every six (6) months or as needed. Use graphite or molybdenum disulfide ("Moly-B") dry lubricant. DO NOT apply too much lubricant.

**Card Readers:**

- **Magnetic Card (All Terminals):** Magnetic Card Readers contain magnetic heads like those on a tape recorder. Depending on usage and environment (dusty), clean heads daily or every other day to reduce the number of bad reads. Magnetic heads require periodic replacement.
- **Proximity:** Proximity readers are intended to be maintenance-free. A proximity reader that will not recognize a compatible card should always be tested, first with multiple cards and then replaced if necessary.

**Heaters:** Units equipped with heaters should be checked for correct operation at the start of each cold season.



**NOTE:** The heater turns on at a temperature of 50°F (10°C). The heater turns off at 70°F (21°C).

## Appendix A - PV100<sup>®</sup> Primary Board

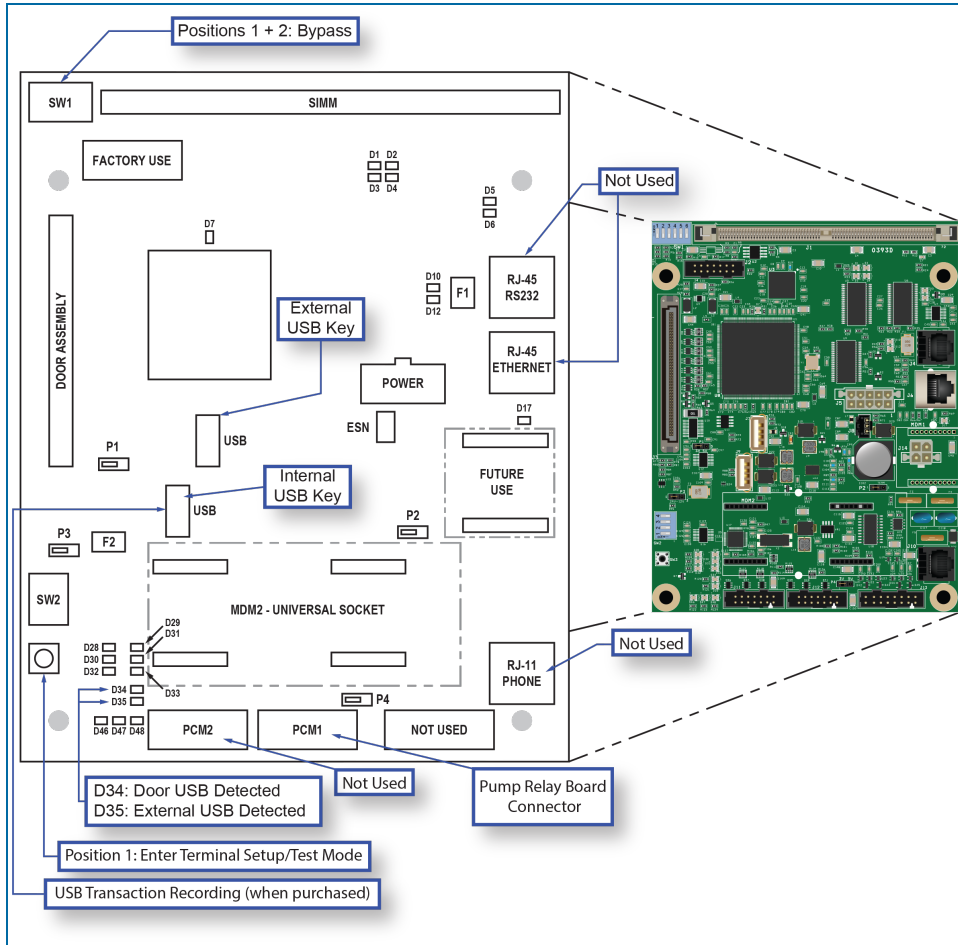

PV100<sup>®</sup> Primary Board



## Appendix B - Termination Codes

Code	Description	Cause (Authorization Denied)	Possible Solution
e	User entry time-out	Customer did not finish entering a prompt before time limit was exceeded	Increase prompt time-out on FIT configuration
f	Card # not in positive file	Card not in card file	Verify card is in the card file, verify card number is correct
i	Card invalidated	Proprietary Card or Network Card Type invalidated	Proprietary Cards – Change card validation to valid in card file Network Cards – Change card validation on ISO table
j	Three bad PIN entries	Customer has entered three (3) bad PINs	Verify user has correct PIN, verify user's PIN is correct in card file
m	Denied Transaction	System is closed	
z	Manager Mode	See " <a href="#">Transactions Report</a> " on <a href="#">page 54</a>	

Code	Description	Cause (Authorization Denied)	Possible Solution
C	Pump error, premature Busy		
D	Pump error – reset quantity exceeded	<p>One (1) unit of pulse(s) being received by the pump controller without sensing the pump is “on”</p> <p>PCT – Handle or Current sense</p> <p>PCM – Handle or Voltage sense</p> <p>K800 Hybrid – Current sense</p>	Verify pump controller is set up for the correct sensing method, verify pump wiring is correct
E	No “pump handle busy”	Pump controller sensed pump on, pulses were never received and the first pulse timer was reached	Verify pulser is working; verify pulser wiring
F	No fueling pulse	Pump controller sensed pump on, pulses were never received and the first pulse timer was reached.	Verify pulser is working Verify pulser wiring
G	Pump currently active	Pump nozzle is engaged	Stop fueling and hang-up the nozzle
I	Normal	Transaction terminated normally	
J	Quantity limit exceeded	One of the quantity limits for the transaction has been reached	Verify pump, card/account record quantity limits are adequate and adjust accordingly
K	Total transaction timeout exceeded	Total transaction timeout exceeded	Verify total transaction fueling time is adequate for the pump and adjust accordingly
L	Pulser error	Only on flow switch applications; pulses not being received within five (5) seconds after the flow switch activation	Verify pulser is working, verify pulser wiring, verify flow switch is not bad
N	Missing pulse detected	Pump controller sensed pump on, pulses	
O (01)	Communication error	The transaction was terminated because communication was lost with the pump controller	Verify communication wiring is properly installed, verify site power conditions

## Appendix C - Menu of Display Screens



**TIP:** Click the cross-referenced headers to go directly to the linked topic.

### "Terminal Setup/Test Menu" on page 31

1. "Display Menu" on page 32
  - a. Mode
  - b. Normal Screen Test
  - c. Inverse Screen Test
2. "Keypad Menu" on page 32
  - a. Numeric/Function Keypad Test
3. "Reader Menu" on page 33
  - a. Select Reader
  - b. Reader Status
4. "Tones Menu" on page 33
  - a. Tone Sequence Test
  - b. Keypad/Prompt/Reader
    - i. Tone Value
    - ii. Tone Duration
5. "System Network Number Menu" on page 34
  - a. Network ID
6. Petro-Net "Petro-Net™ Setup Menu" on page 34 (Not available)
7. "Miscellaneous Menu" on page 34
  - a. Lights Test
  - b. DIP Switch Test
  - c. RAM Loopback Test
  - d. USB Test
  - e. PCM Test
  - f. Restore Factory Defaults

8. "Pump Control Menu" on page 35
  - a. Pump Control
  - b. Pump Simulator Mode
  - c. Fixed Pump Number
9. "Software Updates" on page 36
  - a. Update Application
  - b. Update FPGA
  - c. Update USB driver

## "Management Menu" on page 36

1. "Site Management" on page 37
  - a. Site ID Number
  - b. Date/Time Setup
    - i. Date Format
    - ii. Time Format
    - iii. Open Time
    - iv. Close Time
    - v. Light On
    - vi. Light Off
    - vii. Set Date/Time
      - Set Time
      - Set Day
      - Set Date
      - Set Month
      - Set Year
  - c. Keyboard
    - i. Allow Keyboard Entry
    - ii. Prompt Time-Out
    - iii. Error Message Time-Out
  - d. Manager Cards
    - i. Reset Card 1
    - ii. Reset Card 2
    - iii. Force Manager PIN
    - iv. Lock Reset

- e. Set Options
- f. Site Operation When USB not present
- 2. "Pump Management" on page 40
  - a. Select Pump Terminal
  - b. Select Relay Position
  - c. Configure Pump
    - i. Pump Number
    - ii. Pulse Count
    - iii. Max Quantity
    - iv. Ignore Handle
    - v. Set Totalizer
    - vi. Pump Sentry
  - d. Timeouts
    - i. Handle
    - ii. First Pulse
    - iii. Missing Pulse
    - iv. Total Transaction
- 3. "Proprietary Card File (PCF) Management" on page 41
  - a. Setup PCF
    - i. Pump Restriction Setup
      - Select Card
      - Select Card Range
      - Select Allowed Pumps
    - ii. PIN Setup
      - Disable PIN Entry
      - Set specific PIN
      - All User Selectable
      - Card Invalid After 3 Bad Entries
  - b. View Pump Restrictions
- 4. "Clearing Totals" on page 43
  - a. All Cards
  - b. All Cards and Pumps
  - c. Single Card

- d. Single Pump
- e. Bypass Totals
- 5. "Reporting" on page 44
  - a. View Pump Totals
  - b. View Card Totals
  - c. View Bypass Totals
  - d. Pump Totals to USB
  - e. Card Totals to USB
  - f. Transactions to USB

## Warranty

OPW Fuel Management Systems warrants that all OPW Tank Gauge and Petro Vend Fuel Control systems supplied by OPW Fuel Management Systems to the Original Purchaser will be free from defects in material and/or workmanship under normal use and service for a period of 12 months from the date of installation or 15 months from the date of shipment from OPW. Additionally, OPW Fuel Management Systems warrants that all upgrades and replacement parts (new and remanufactured) supplied by OPW Fuel Management Systems will be free from defects in material and workmanship under normal use and serviced for a period of 90 days from the date of installation or for the remainder of the system's original warranty, whichever is greater, as set forth in the first sentence of this statement. The foregoing warranties will not extend to goods subjected to misuse, neglect, accident, or improper installation or maintenance or which have been altered or repaired by anyone other than OPW Fuel Management Systems or its authorized representative. The buyer's acceptance of delivery of the goods constitutes acceptance of the foregoing warranties and remedies, and all conditions and limitations thereof.

If a claim is made within the warranted time period that any equipment and/or remanufactured part is defective in material or workmanship under normal use and service, such equipment and/or remanufactured part shall be returned to OPW Fuel Management Systems, freight prepaid. If such equipment or remanufactured part is found by OPW Fuel Management Systems in its sole judgment to be defective in material or workmanship under normal use and service, OPW Fuel Management Systems shall, at its sole option, repair or replace such equipment and/or remanufactured part (excluding, in all instances, fuses, ink cartridges, batteries, other consumable items, etc.) OPW Fuel Management Systems shall not be held responsible for data loss or retrieval on returned products.

The warranties, as set forth above, are made expressly in lieu of all other warranties, either expressed or implied (including, without limitation, warranties of merchantability and fitness for any particular purpose and of all other obligations or liabilities on OPW Fuel Management Systems' part.) Further, OPW Fuel Management Systems neither assumes, nor authorizes any other person to assume for it, any other liability in connection with the sale of the systems, or any new/replacement part that has been subject to any damage from any act of nature or any force majeure. Any terms proposed by the Original Purchaser either orally or in writing are expressly rejected. The terms and conditions expressed in this document may only be changed upon the express written consent of OPW Fuel Management Systems.

The term "Original Purchaser" as used in these warranties shall be deemed to mean the authorized OPW Fuel Management Systems' distributor to which the system or any new/replacement part was originally sold. These warranties may be assigned by the original purchaser to any of its customers who purchase any OPW Fuel Management Systems' systems or new/replacement parts. This document shall be governed by and construed in accordance with the law of the State of Illinois. OPW Fuel Management Systems and Original Purchaser agree that any legal action or proceeding under or with respect to this document may ONLY be brought in the courts of the State of Illinois, or the United States District Court having jurisdiction in the City of Hodgkins, Illinois. Original Purchaser expressly consents to personal jurisdiction in any of the above-mentioned forums and agrees to waive all defenses based on improper venue or inconvenient form should an action be brought therein.

The sole liability of OPW Fuel Management Systems, for any breach of warranty, shall be as set forth above. OPW Fuel Management Systems does not warrant against damage caused by accident, abuse, faulty or improper installation or operation. In no event shall manufacturer's liability on any claim for damages arising out of the manufacture, sale, delivery or use of the goods exceed the original purchase price of the goods. In no event shall OPW Fuel Management Systems be liable for any direct, indirect, incidental or consequential damage or loss of product.

### TERMS

Ex-works our factory, Hodgkins, Illinois, USA

Installation not included.

All trade names are registered. Patents pending.

Subject to engineering improvement and/or other changes.

## Revision History

Revision #	ECO #	Effective	Software Version*	Key Changes
0	NA	2/6/13		Initial Release
1	458	6/16/2013		Revised menu content to reflect latest version of menus. Revised installation information and diagrams.
2	517	10/18/2013		Add note to page 17, "After replacing Lexan shield, reinsert the USB cable in the UPPER USB connector on the main board." And on page 32, add note indicating that the second USB port reads: "USB Transaction Recording (when purchased)". Add in QR code at the beginning of the installation section.
3	583	3/3/2014		M1900 PV100 Manual update to Support updated Software (S02002 & S02003) Added Section 2.2 Versioning, Added to Section 6.3.3 Proprietary card file Management, added bullet point config prompt 1. Replaced in Section 6.3.5 Reporting, replaced Figure 6-3 & 6-4 to reflect additions in Section 6.3.3
4	893	6/1/2016	2.01h /3.01.03a	Added installation instructions for new pedestal design. Instructions updated to include support of 4-hose feature upgrade (s/w version 3.01.03a). Reformatted to latest brand standard.
5	1086	2/1/2017	2.01m /3.01.03f	Update to include Dual Card security feature, ChipKey and 1000 cards.
6	1119	2/6/2017		Added Termination codes "m" and "z" to Appendix B
7	1165	5/3/2017		Added Terminal code F
8	1476	12/4/2018		Add missing safety topics, updated Copyright Contact Compliance page, USB definitions. Update PCM photos with new illustrations.



**NOTE:** \*It is possible that older software versions might not support all features.





INNOVATIVE SOLUTIONS FUELING BUSINESS SUCCESS WORLDWIDE

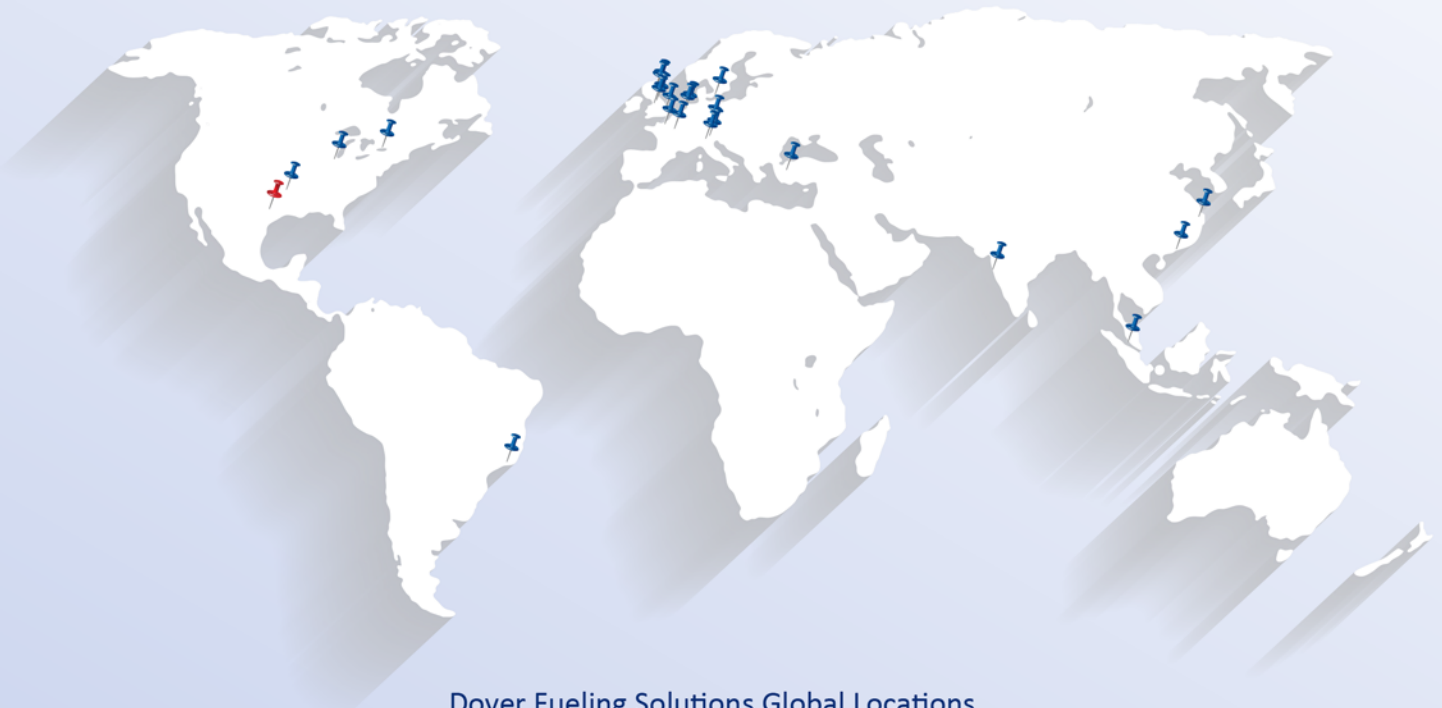

### Dover Fueling Solutions Global Locations

Corporate Headquarters  
3814 Jarrett Way  
Austin, Texas 78728  
United States  
Phone: +1 512 388 8311

**North America**  
Richardson, TX, USA  
Hodgkins, IL, USA  
Brighton, Ontario, CAN

**Latin America**  
Rio de Janeiro, Brazil

Midlothian, UK  
Elland, UK  
Dundee, UK  
London, UK  
Skelmersdale, UK  
Grenthville, FR  
Paris, FR

#### Europe

Munich, DE  
Bladel, NL  
Turnhout, NL  
Malmö, SE  
Bovisio Masciago, IT  
Castione Adevanno, IT  
Turkey

**Asia Pacific**  
Mumbai, IN  
Petaling, MY  
Guangzhou, CN  
Shanghai, CN

OPW Fuel Management Systems • 6900 Santa Fe Dr. • Hodgkins, Illinois, USA 60525 • Tel: (708) 485-4200